

# ROUSH

THE **ART** OF PERFORMANCE ENGINEERING

PREMIUM FUEL REQUIRED

## 2005-06 Ford Mustang GT ROUSHCharger Kit

P/Ns: 13056066M90 (Black) & 13056066M90C (Chrome)

EO#: D-418-13

# Installation Instructions

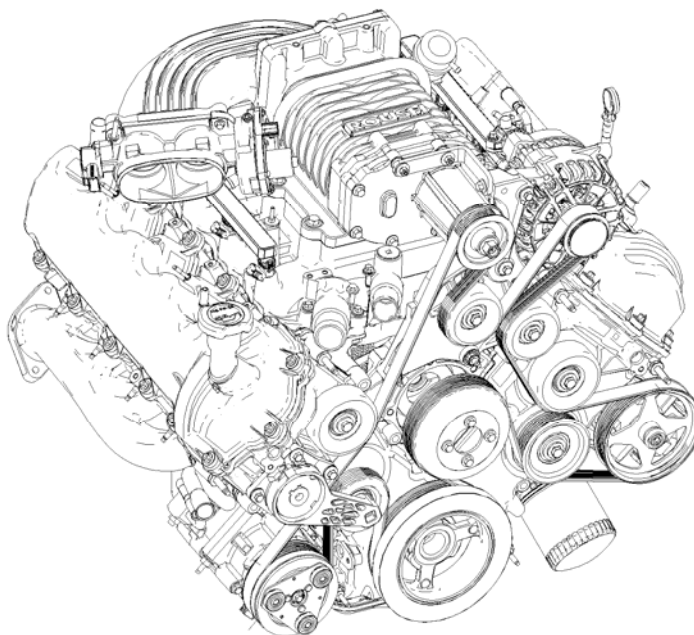

### Applications:

2005-06 Ford Mustang GT 4.6L 3-Valve (w/ Manual & Automatic Transmissions).

### Important Notes:

- ☑ Before installing your Mustang ROUSHcharger Kit, please read the installation manual and verify that all items are present. Contact ROUSH Customer Service at 1-800-59-ROUSH, 9:00 AM to 5:00 PM weekdays, for any questions regarding fit or instructions that are unclear to you.
- ☑ Premium fuel (91 octane or higher) is required to prevent “spark-knock” or detonation under certain operating conditions.
- ☑ The use of fuel additives (ie. octane boosters) is not recommended. There is a possibility that these chemicals can damage your engine and cause drivability issues with your vehicle.
- ☑ Operating your engine without the ROUSH PCM recalibration will result in engine damage or failure and will void your warranty.

# ROUSH

THE ART OF PERFORMANCE ENGINEERING

PREMIUM FUEL REQUIRED

## TABLE OF CONTENTS

PACKAGING LIST FOR COMPLETE ROUSHCHARGER KIT.....	3
EQUIPMENT AND SUPPLIES REQUIRED .....	17
GLOSSARY OF TERMS.....	18
INFORMATION ABOUT THE SUPERCHARGER BYPASS OPERATION .....	18
LIMIT OF LIABILITY STATEMENT .....	19
SAFETY PRECAUTIONS .....	19
SECTION A – DISASSEMBLY.....	20
SECTION B – MODIFICATIONS .....	30
Alternator Modification.....	30
Coolant Hose Hanger Modification.....	31
Airbox Modification .....	32
Heater Tube Assembly Modification .....	34
Wiring Harness Modifications .....	35
SECTION C – SUBASSEMBLY .....	41
Intake Manifold Build Up.....	41
Fuel Rail Assembly.....	42
SECTION D – INSTALLATION .....	43
Intercooler Reservoir Mounting.....	43
Intercooler Radiator Assembly Mounting.....	46
Electric Water Pump Bracket Mounting.....	49
Electric Water Pump Harness.....	52
Spark Plug Installation.....	54
Intake Manifold and ROUSHCharger Installation .....	54
FEAD Assembly .....	59
Air Intake System .....	63
Coolant Hoses .....	65
Air Induction System.....	67
Battery and Tray.....	68
Vacuum System Connections.....	68
Coolant Fill and Final Assembly .....	70
CARE AND MAINTENANCE OF OPTIONAL POLISHED ROUSHCHARGER.....	73
WARRANTY.....	73

# ROUSH

THE **ART** OF PERFORMANCE ENGINEERING

PREMIUM FUEL REQUIRED

## PACKAGING LIST FOR COMPLETE ROUSHCHARGER KIT

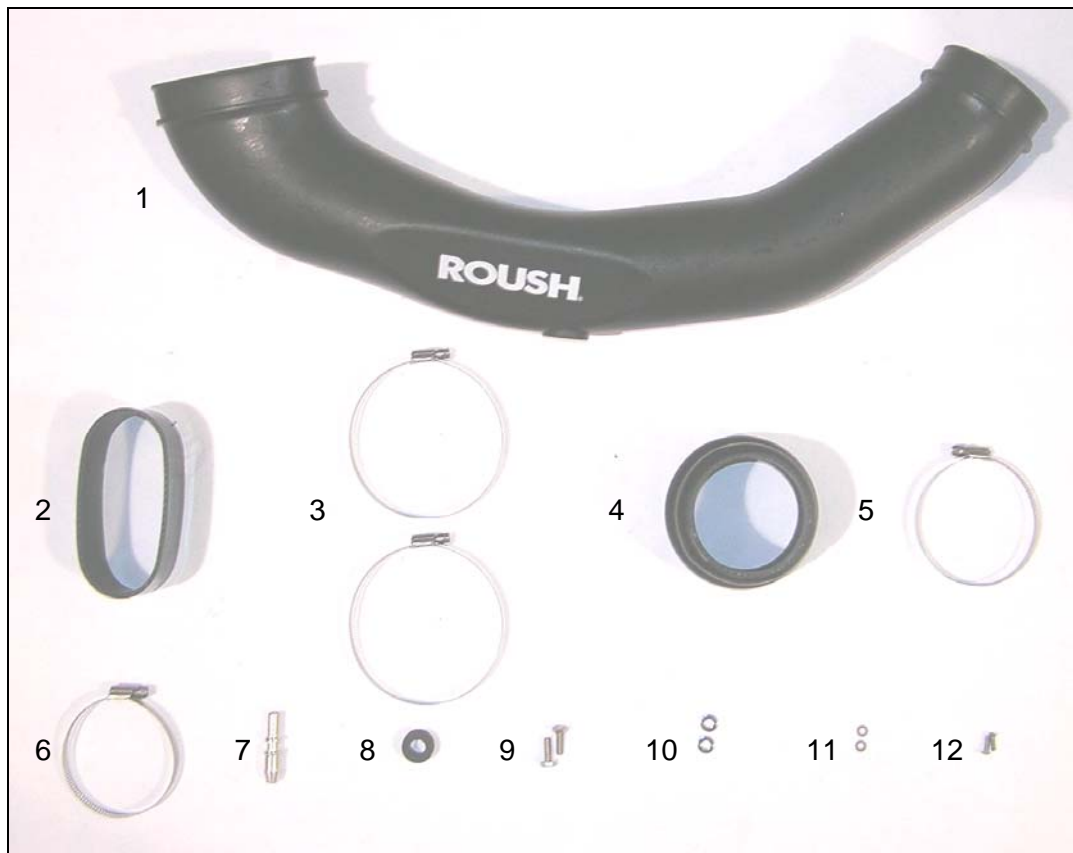

Part Ref	Description	RPP Part Number	Qty
	<b>Induction Kit</b>	<b>R07060059</b>	<b>1</b>
1	Clean Air Tube	R07060026	1
2	Coupler - Throttle Body End	R07060029	1
3	#72 Hose Clamp (Throttle Body)	----	2
4	Hump Hose – Air Box End	R07060030	1
5	#56 Hose Clamp (Tube side)	----	1
6	#52 Hose Clamp (Air Box side)	----	1
7	SAE Fitting - PCV Insert	----	1
8	Rubber Grommet - PCV Insert	----	1
9	1/4 20 X 5/8 Screw (Support Bracket)	----	2
10	1/4 Washers (Support Bracket)	----	2
11	#8 Washers (MAF)	----	2
12	8/32 Screws (MAF)	----	2

# ROUSH

THE ART OF PERFORMANCE ENGINEERING

PREMIUM FUEL REQUIRED



Part Ref	Description	RPP Part Number	Qty
	<b>Hardware Kit A - Air Box Modifications</b>	<b>R07060060</b>	<b>1</b>
13	Air Inlet	R07060061	1
14	Bellmouth Insert	R07060062	1
15	Adhesive - Loctite 4210 (3gm Tube)	R18090001	1

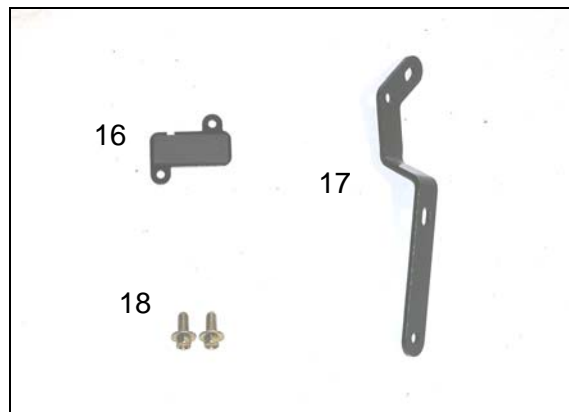

Part Ref	Description	RPP Part Number	Qty
	<b>Hardware Kit B - Induction</b>	<b>R07060064</b>	<b>1</b>
16	MAF Block-Off Plate w/ Gasket	R07060065	1
17	Bracket- Tube Support	R07060066	1
18	Bolts - Support Bracket to Intake (M6 x 1.0 x 13)	N605771-S309	2

# ROUSH

THE ART OF PERFORMANCE ENGINEERING

PREMIUM FUEL REQUIRED



**NOTE:** The Fuel Charging Assembly (R07060083) is shown above. It has been pre-assembled by ROUSH to ensure quality and simplify installation. It consists of parts 19 thru 34 which are shown individually below for reference only.

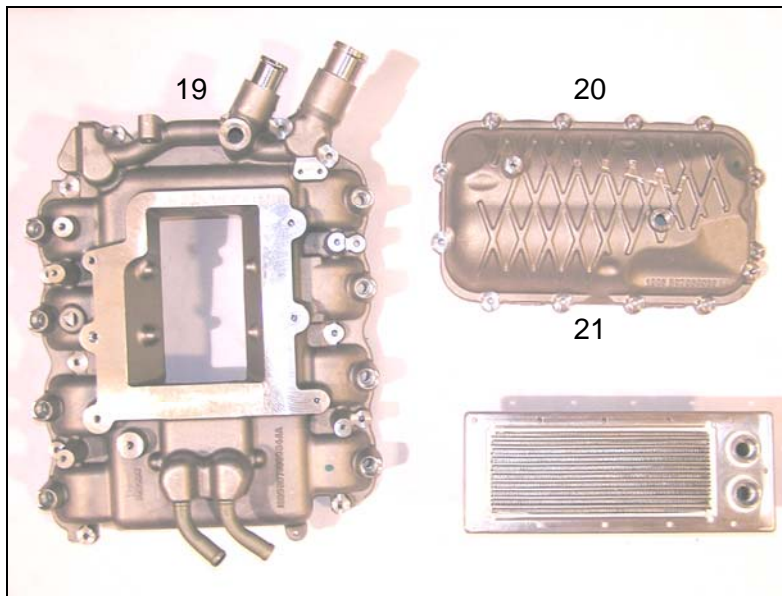

Part Ref	Description	RPP Part Number	Qty
	<b>Fuel Charging Assembly</b>	<b>R07060083</b>	<b>1</b>
19	Upper Intake Manifold	R07060034	1
20	Lower Intake Manifold	R07060039	1
21	Intercooler	R07060171	1

# ROUSH

THE ART OF PERFORMANCE ENGINEERING

PREMIUM FUEL REQUIRED

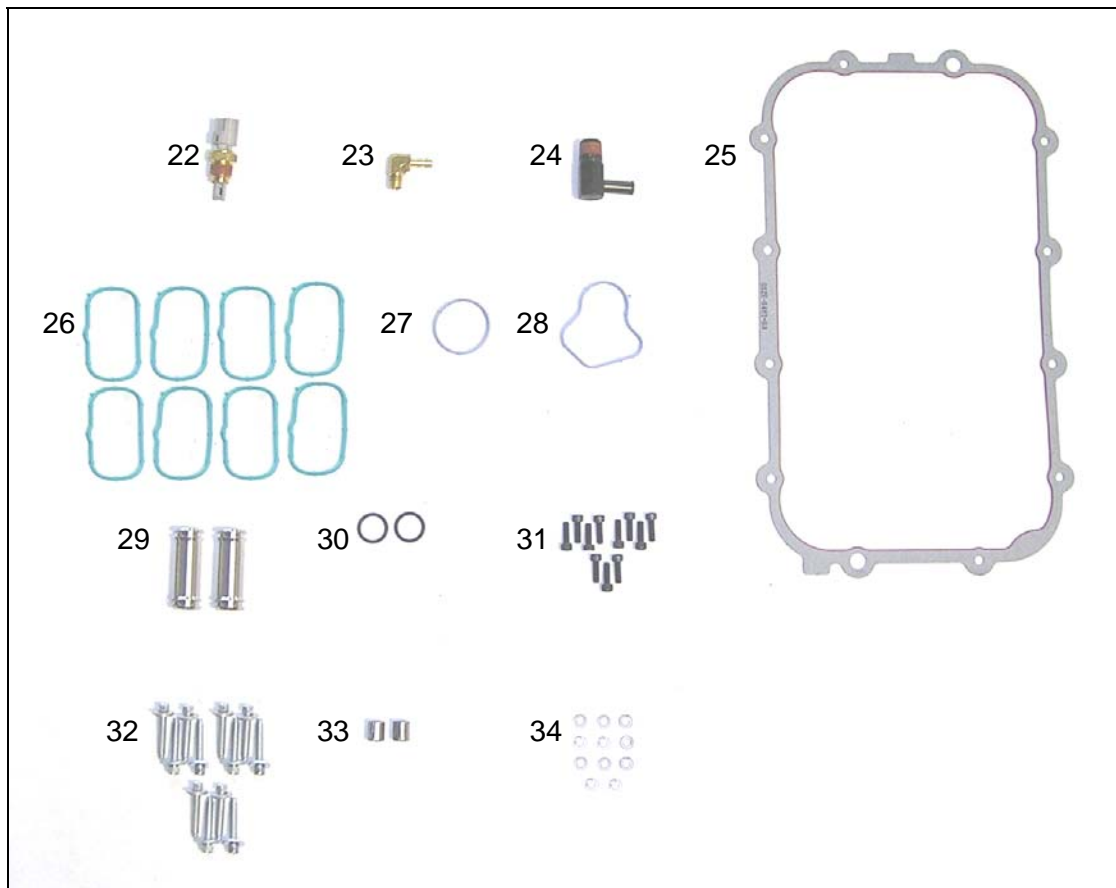

Part Ref	Description	RPP Part Number	Qty
	<b>Fuel Charging Assembly...Continued</b>	<b>R07060083</b>	<b>1</b>
22	ACT Sensor	F6SF-12A697-AB	1
23	Fitting - 90 deg. IPTS Reference (1/4")	53525K11	1
24	Fitting - 90 deg. PCV Bubbler (3/8")	391273-S100	1
25	Gasket - Upper to Lower	G1ZE-9461-BB	1
26	Gasket - Intake Manifold Ports	R07060045	8
27	Gasket - Water Crossover Right	R07070001	1
28	Gasket - Water Crossover Left	R07070002	1
29	Billet Tube - Intercooler Floating Tubes	G1ZE-9L442-AA	2
30	O-Ring - Floating Tube	2-115	4
31	Bolt - Intercooler to Intake (M5 x 0.8 x 16)	SCS-05016-YZ	11
32	Bolt - Upper to Lower Intake (M6 x 1.0 x 33)	N808429-S437	12
33	Dowel - Intake to Supercharger	388192-S	2
34	Washer - Intercooler to Intake	11-452-0033	11

# ROUSH

THE **ART** OF PERFORMANCE ENGINEERING

PREMIUM FUEL REQUIRED

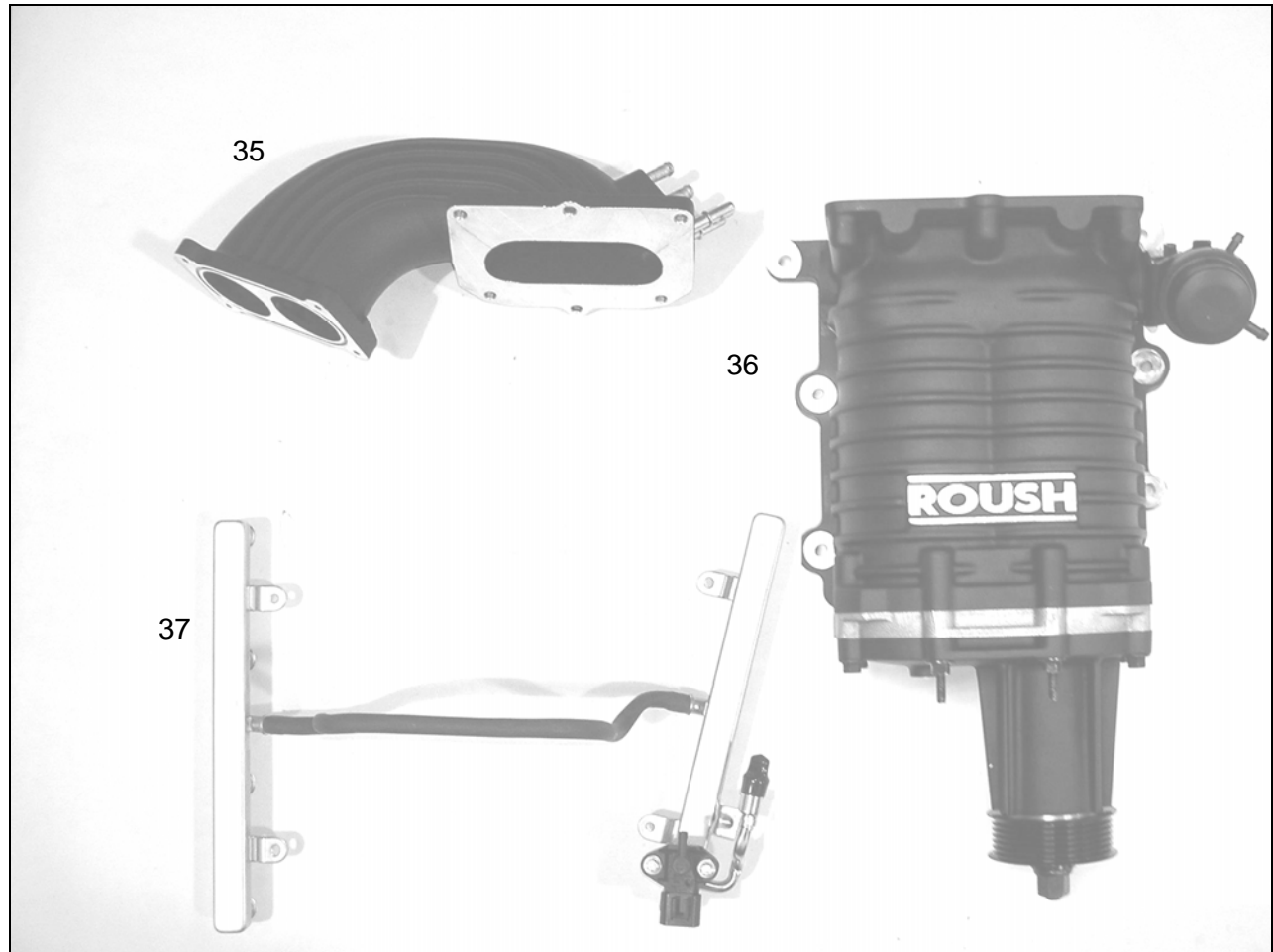

Part Ref	Description	RPP Part Number	Qty
35	Throttle Spacer	R07060041	1
36	ROUSHCharger – Black	R07050086	1
Optional	ROUSHCharger – Chrome	R07050120	1
37	Fuel Rail	R07110001	1

# ROUSH

THE ART OF PERFORMANCE ENGINEERING

PREMIUM FUEL REQUIRED

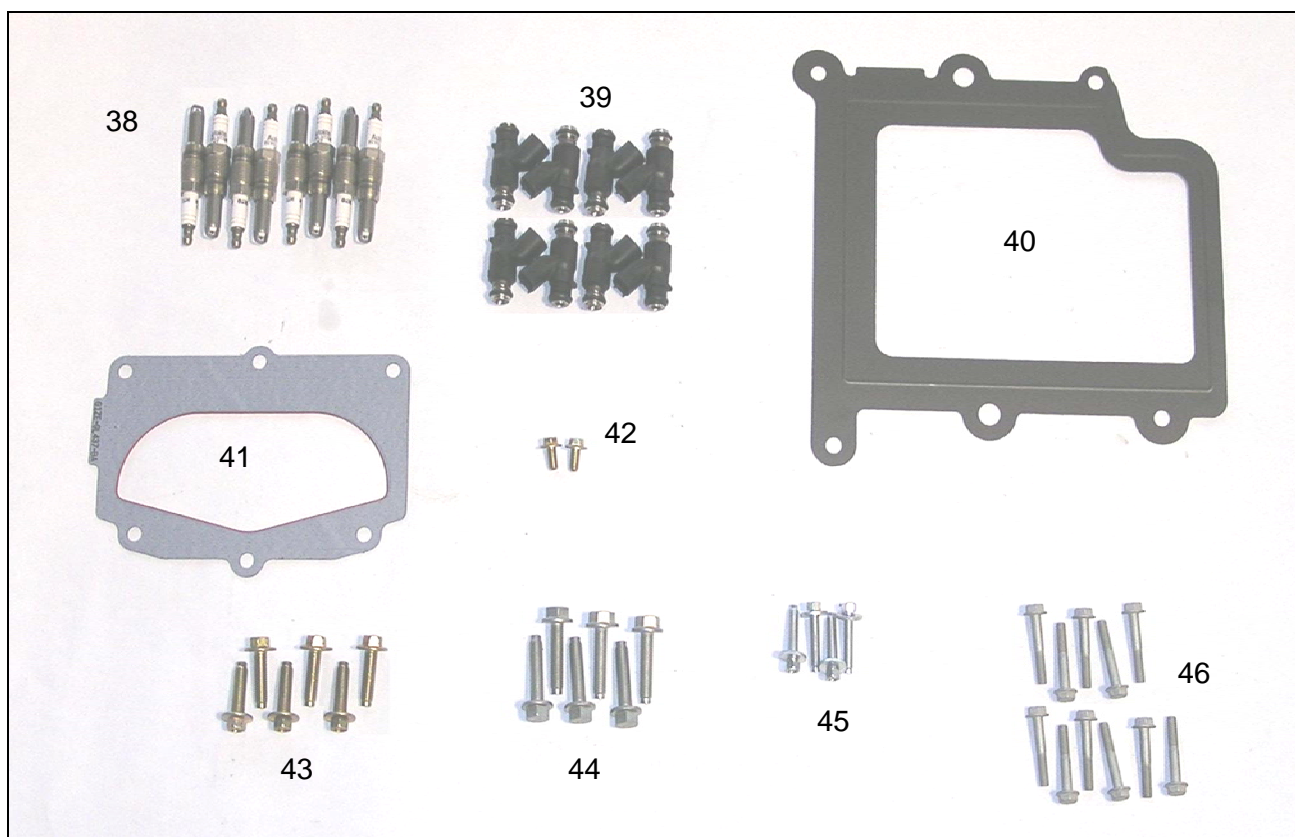

Part Ref	Description	RPP Part Number	Qty
	<b>Hardware Kit C - Intake</b>	<b>R07060046</b>	<b>1</b>
38	Spark Plugs	R07030001	0*
39	Fuel Injectors	R14010001	8
40	Gasket - Intake to Supercharger	G1ZE-9H486-BA	1
41	Gasket - Supercharger to Spacer	G1ZE-9L437-BA	1
42	Bolt - Heater Supply Tube Mounting (M6 x 1.0 x 13)	N605771-S309	2
43	Bolt - Spacer to Supercharger (M8 x 1.25 x 33)	N808920-S309	6
44	Bolt - Supercharger to Intake (M8 x 1.25 x 38)	W705128-S437	6
45	Bolt - Throttle Body (M6 x 1.0 x 33)	N808429-S437	4
46	Bolt - Intake to Cylinder Heads (M6 x 1.0 x 40)	R18020004	11

**\*Note:** Spark plugs will be shipped with your re-flashed PCM as required.



# ROUSH

THE **ART** OF PERFORMANCE ENGINEERING

PREMIUM FUEL REQUIRED

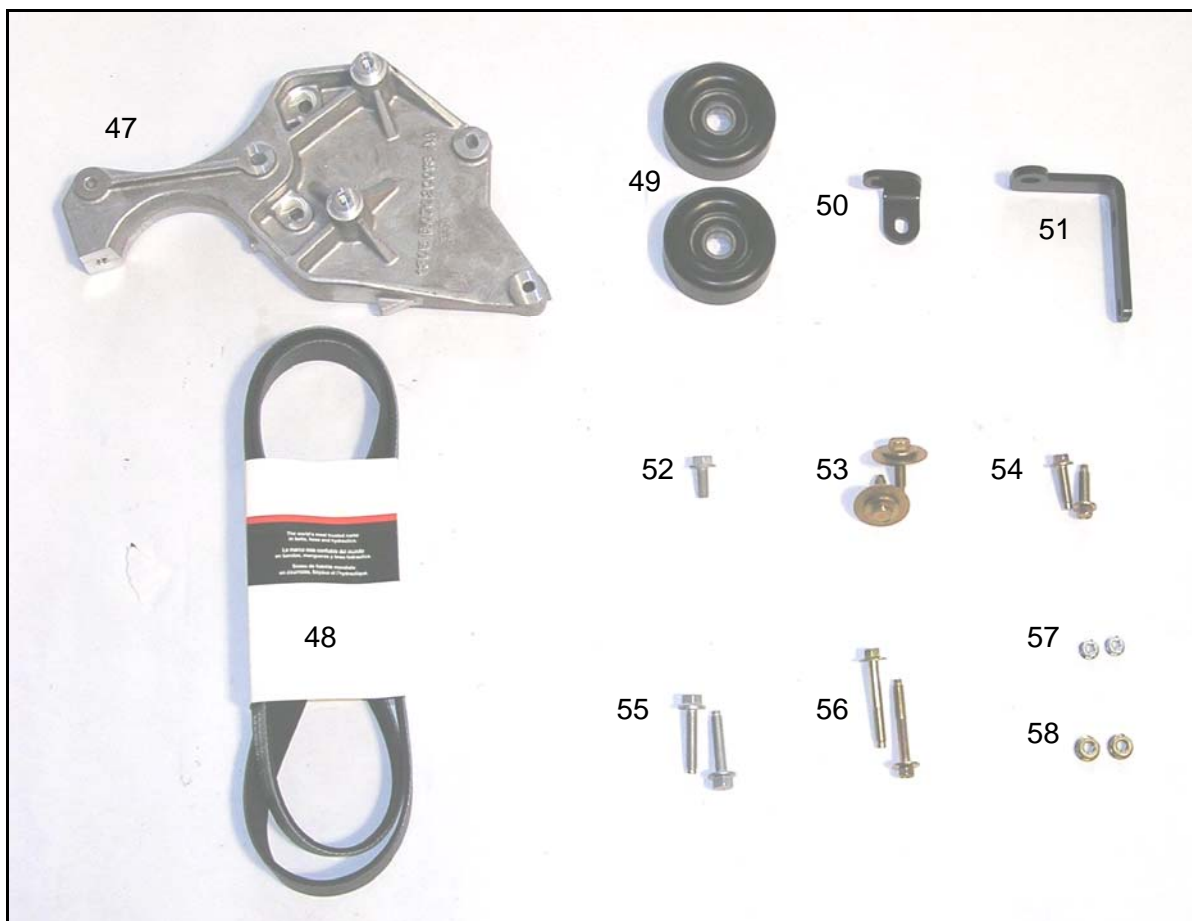

Part Ref	Description	RPP Part Number	Qty
47	Alternator Bracket	R07020013	1
48	Serpentine FEAD Belt	R07020015	1
	<b>Hardware Kit D - FEAD</b>	<b>R07020064</b>	<b>1</b>
49	Pulley - Idler B/S 76mm Flanged	R07020049	2
50	Bracket - Intake to Alternator Rear	R07020017	1
51	Bracket - Supercharger Studs to Alternator Bracket	R07020018	1
52	Bolt - Alternator Support Bracket Rear (M8 x 1.25 x 20)	R18020005	1
53	Bolt - Idler (M8 x 1.25 x 28 large washer)	R18020060	2
54	Bolt - Alternator Support Brkts to Intk & FEAD Brkt (M8 x 1.25 x 25)	W500224-S309	2
55	Bolt - FEAD Bracket to Intake (M8 x 1.25 x 38)	W705128-S437	2
56	Bolt - Alternator (M8 x 1.25 x 55)	N808130-S309	2
57	Nut - Supercharger to Alternator Support Bracket Front (M6)	W520412-S309	2
58	Nut - Alternator (M8)	W520413-S309	2

# ROUSH

THE ART OF PERFORMANCE ENGINEERING

PREMIUM FUEL REQUIRED

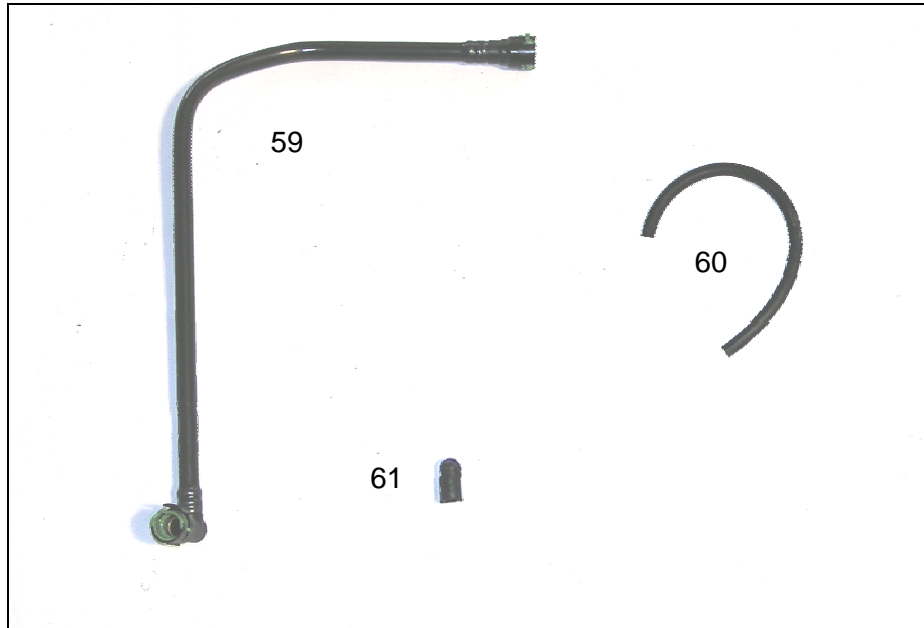

Part Ref	Description	RPP Part Number	Qty
	<b>Hardware Kit E - PCV &amp; Vacuum</b>	<b>R07040005</b>	<b>1</b>
59	PCV Purge	R07040006	1
60	Vacuum Hose - Supercharger Bypass Circuit	R18140001	1
61	Vacuum Cap - Throttle Spacer	R07040040	1

# ROUSH

THE **ART** OF PERFORMANCE ENGINEERING

PREMIUM FUEL REQUIRED

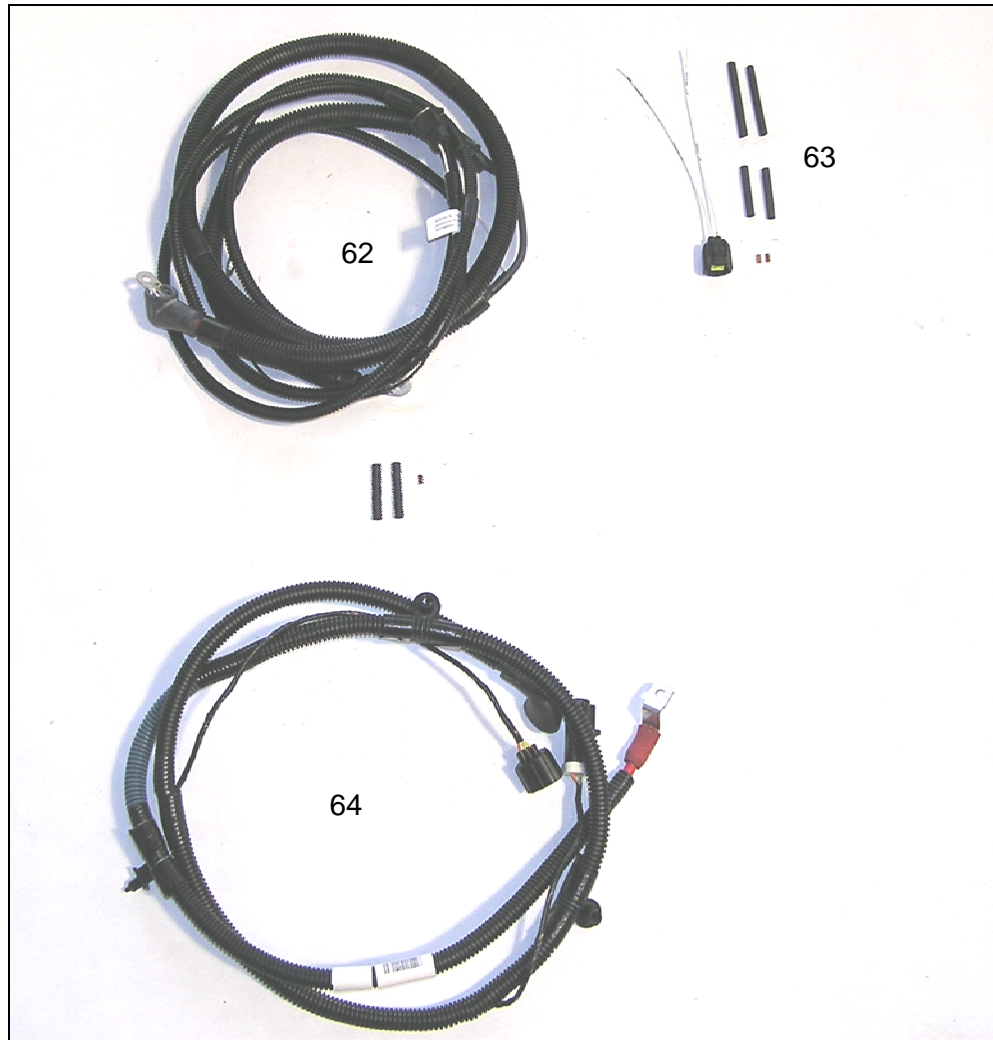

Part Ref	Description	RPP Part Number	Qty
	<b>Hardware Kit F - Wiring</b>	<b>R07080004</b>	<b>1</b>
62	Electrical Jumper - Intercooler Pump	R07080006	1
63	Electrical Jumper - ACT	1104-12B637-BA	1
64	Alternator Charge Harness	R07080015	1

# ROUSH

THE **ART** OF PERFORMANCE ENGINEERING

PREMIUM FUEL REQUIRED

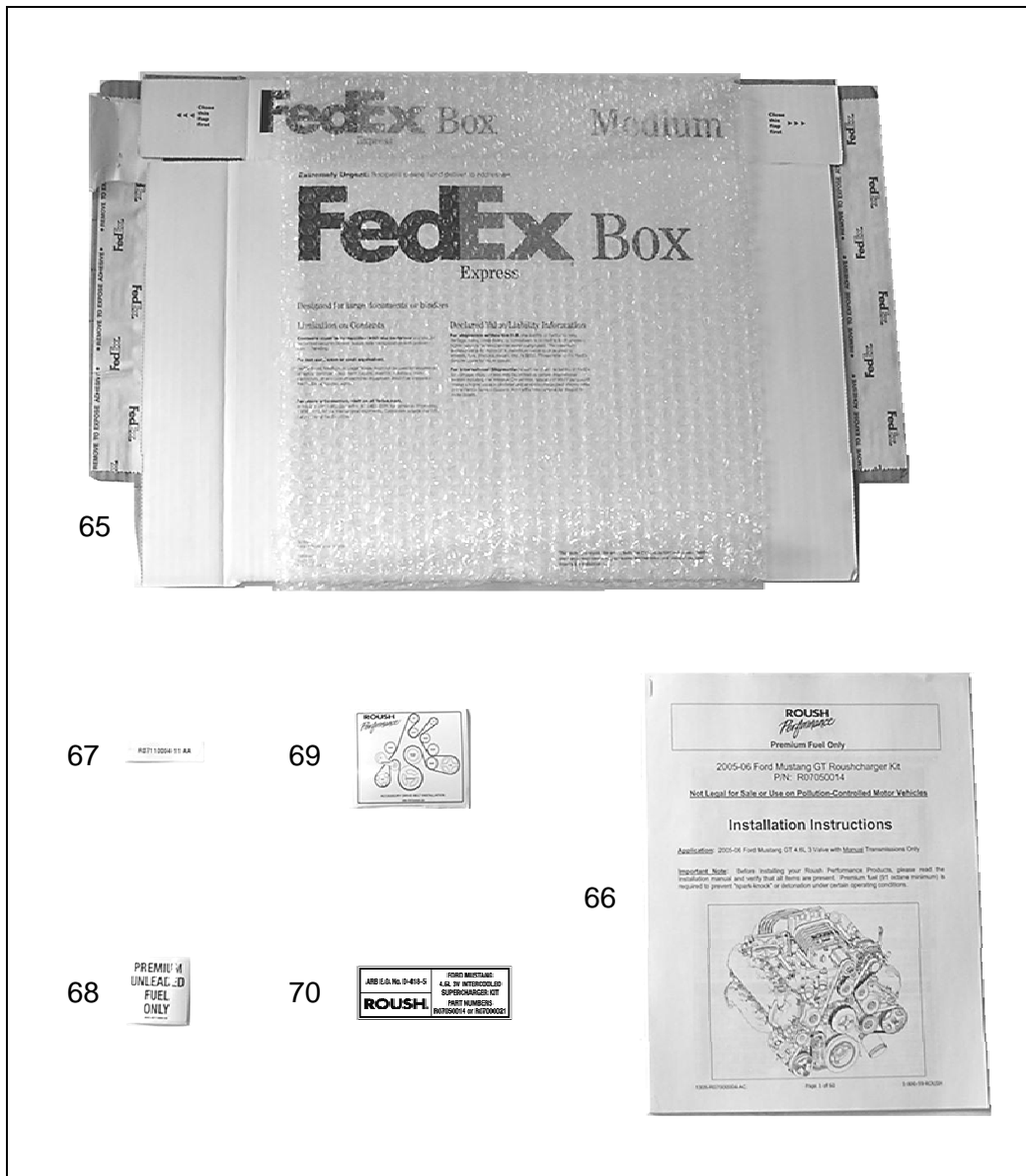

Part Ref	Description	RPP Part Number	Qty
65	Box- PCM Return	R07140023	1
66	Installation Manual	13056066M90IM	1
	<b>Hardware Kit G - Decals</b>	<b>R07040052</b>	<b>1</b>
67	Decal - Premium Fuel Only (IP Cluster)	R07110004	1
68	Decal - Premium Fuel Only (Fuel Door)	R07110003	1
69	Decal - 2005 Mustang Supercharged Belt Routing Diagram	13106E072	1
70	E.O. Decal (2005-09 Models)	R09000009	1
	Warranty Card	131019A505	1

# ROUSH

THE ART OF PERFORMANCE ENGINEERING

PREMIUM FUEL REQUIRED

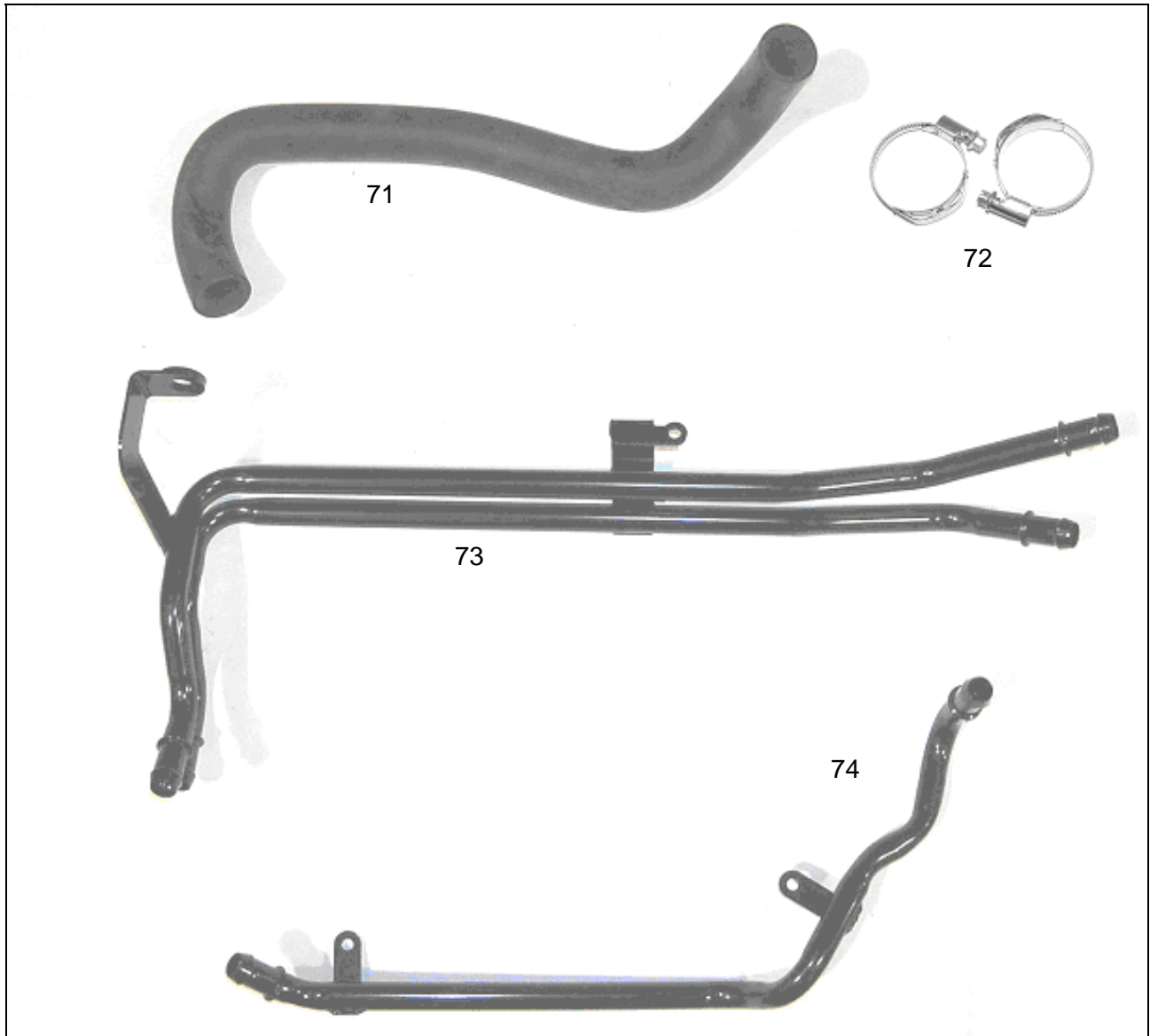

Part Ref	Description	RPP Part Number	Qty
	<b>Hardware Kit I - Hose, Tubing, and Clamps</b>	<b>R07010001</b>	<b>1</b>
71	Bypass Circuit Radiator Hose	R07070004	1
72	Clamps - 1.25" Radiator Hose		2
73	Tube Assembly - Intercooler	R07070005	1
74	Tube - Heater Supply	R07070014	1

# ROUSH

THE ART OF PERFORMANCE ENGINEERING

PREMIUM FUEL REQUIRED

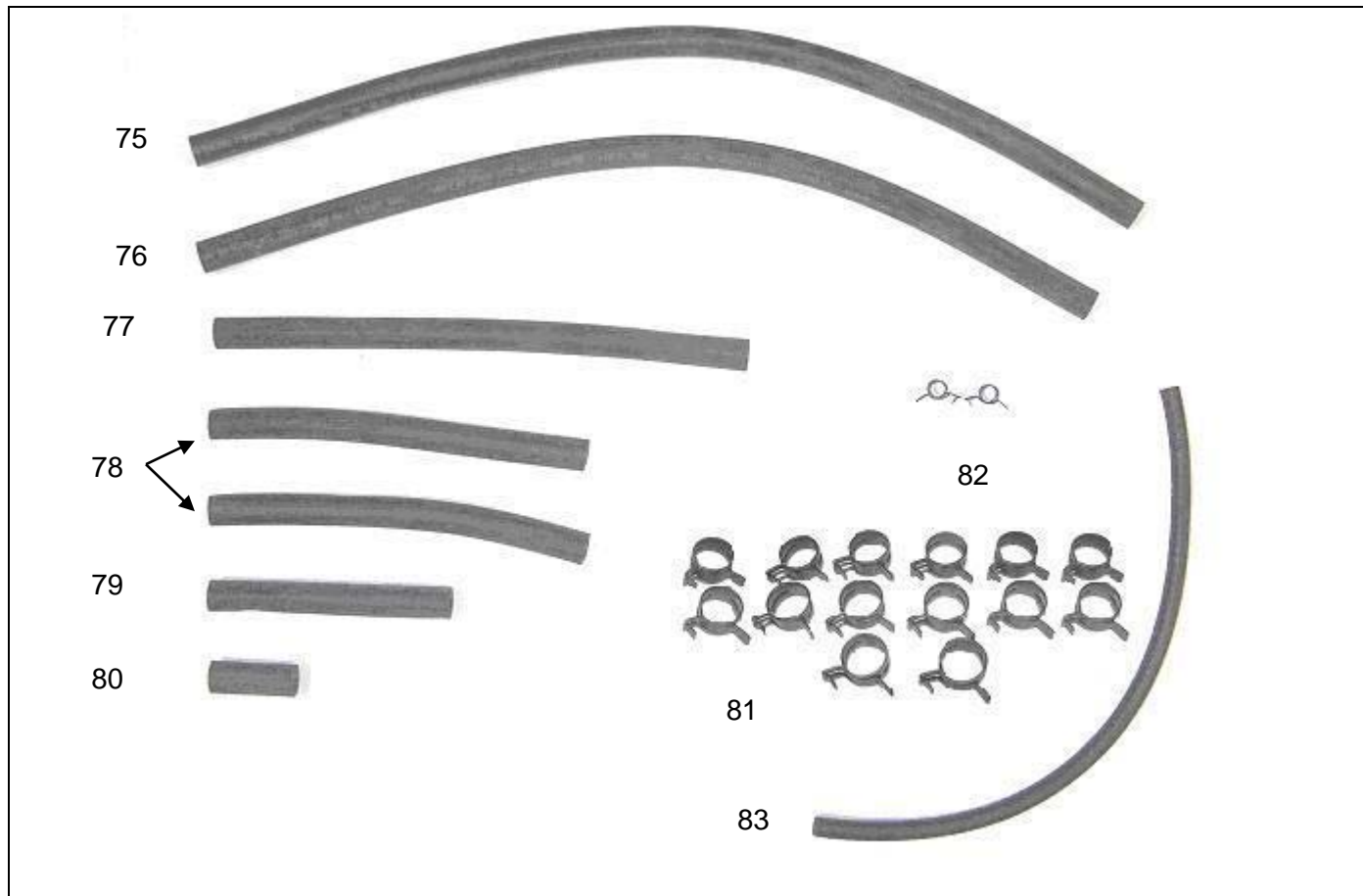

Part Ref	Description	RPP Part Number	Qty
	<b>Hardware Kit I - Hose, Tubing, and Clamps...Continued</b>	<b>R07010001</b>	<b>1</b>
75	3/4" Hose - LTR Outlet		1
76	3/4" Hose - Degas Outlet		1
77	3/4" Hose - Degas Inlet		1
78	3/4" Hose - LTR Inlet & I/C Outlet		2
79	3/4" Hose - Intercooler Inlet		1
80	3/4" Hose - Heater Supply		1
81	Clamps - 3/4" Hoses (Constant Tension)		14
82	Clamps - PCV Bubbler		2
83	PCV Bubbler Hose	R07040007	1

# ROUSH

THE ART OF PERFORMANCE ENGINEERING

PREMIUM FUEL REQUIRED

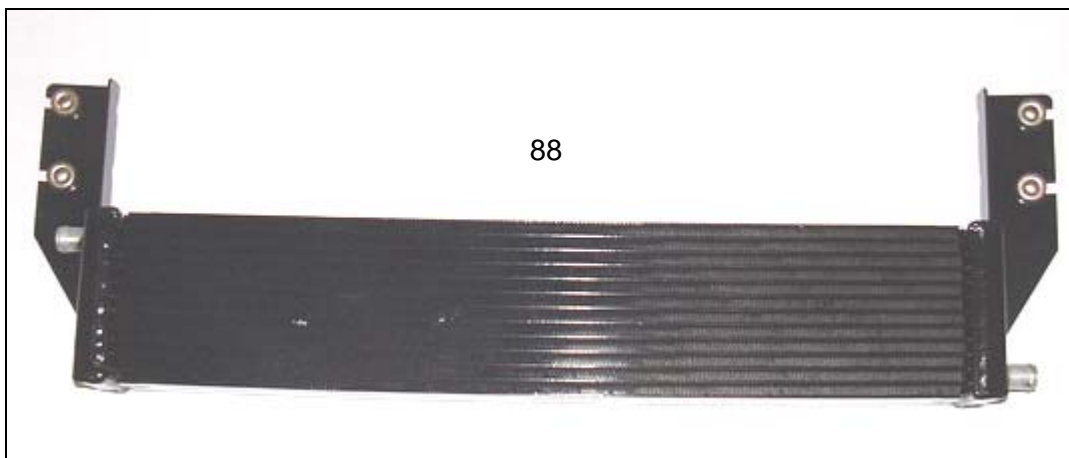
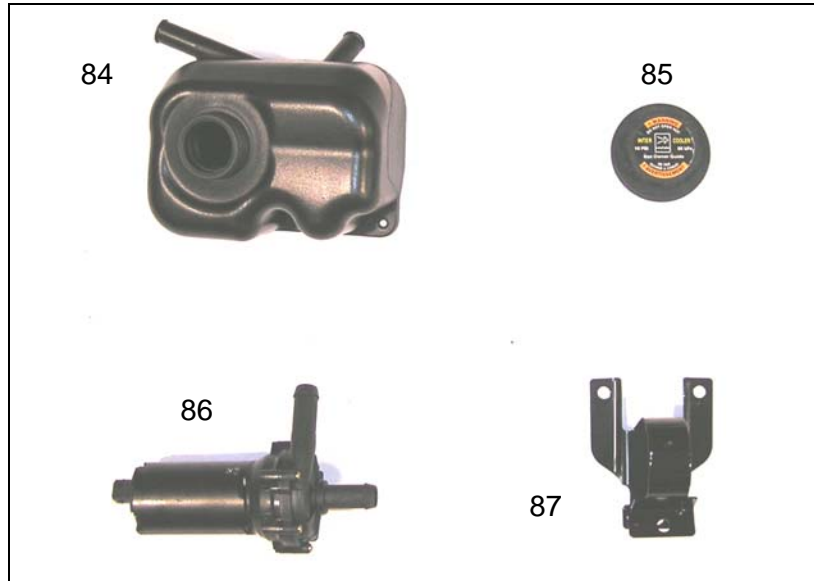

Part Ref	Description	RPP Part Number	Qty
84	Degas Bottle	R07070007	1
85	Degas Bottle Cap	XL3Z-8100-AA	1
86	Intercooler Electric Water Pump	F8YZ-8501-AA	1
87	Bracket - Intercooler Pump Mounting	R07070015	1
88	Intercooler Low Temp Radiator (LTR)	R07070047	1

# ROUSH

THE ART OF PERFORMANCE ENGINEERING

PREMIUM FUEL REQUIRED

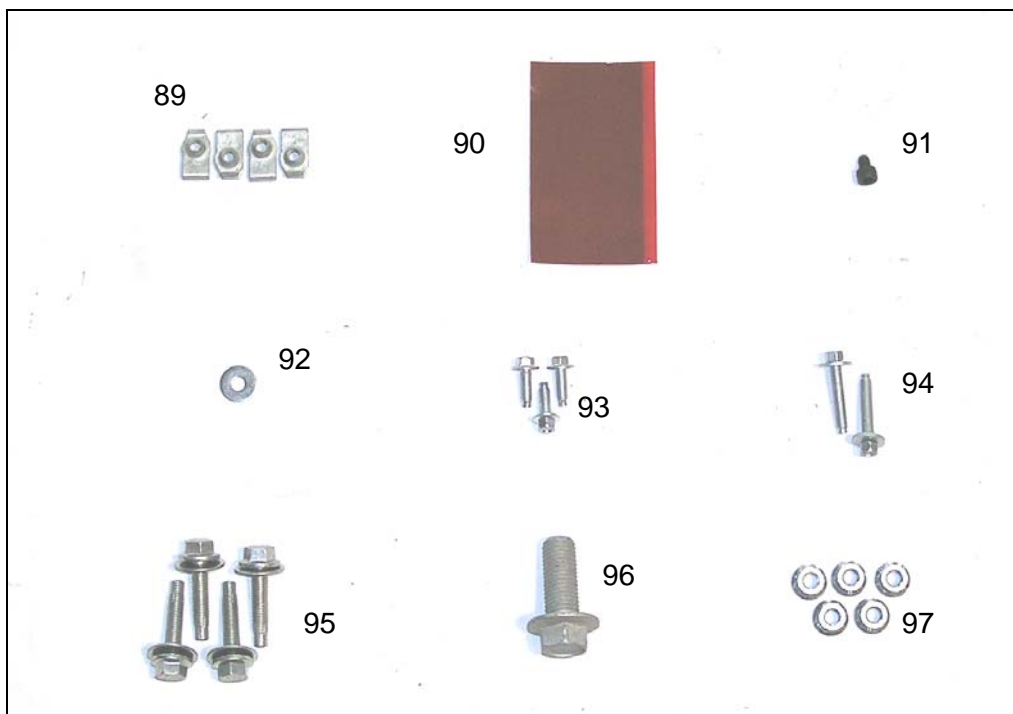

Part Ref	Description	RPP Part Number	Qty
	<b>Hardware Kit J - Intercooler Circuit Fasteners</b>	<b>R07070016</b>	<b>1</b>
89	J-Clip - Degas Bottle & Pump Bracket Mounting (M6 Short)	N623332-S301	4
90	Double-Sided Tape - Degas Bottle Mounting	R07030002	1
91	Cap Screw - Degas Bottle Mounting (M6 x 1.0 x 8)	R18020010	1
92	Washer - M6	R18030002	1
93	Bolt - Pump Bracket (2) & I/C Tube Assembly Mounting (1) (M6 x 18)	N605891-S437	3
94	Bolt - Degas Bottle Mounting (M6 x 1.0 x 33)	N808429-S437	2
95	Bolt - Long Bumper Bolts (M8 x 1.25 x 35)	R18020007	4
96	Bolt - 9N491 Tube Assembly Mounting (M16 x 40)	R18020006	1
97	Nut - LTR Mounting (4) & Pump Bracket (1) (M8)	W520413-S309	5

**If you are missing any items, please call us toll free at 1-800-59-ROUSH.**



# ROUSH

THE ART OF PERFORMANCE ENGINEERING

PREMIUM FUEL REQUIRED

## EQUIPMENT AND SUPPLIES REQUIRED

- 1/4" and 3/8" Drive Ratchets with Extensions
- Metric and Standard Socket Sets (short and deep recommended)
- 1/2" Drive Ratchet or Breaker Bar
- Metric and Standard Wrench Sets
- 3/8" Drive Torque Wrench (7-35 ft-lb range)
- Short Phillips-head Screwdriver
- Hex Key Set
- Teflon pipe sealing tape or equivalent
- 5/8" Fuel Line Removal Tool
- T-20 Torx Bit Screwdriver or Socket
- Soldering Iron and Solder
- Wire Strippers
- Wire Crimpers "W" type for OEM-style wiring connectors
- 1/8", 9/64", and 1/4" Drill Bits and Drill motor
- Coolant (meeting G-05 specification)
- 6" Scale, Tape Measure, or Other Measuring Device
- Brake Parts Cleaner
- Assembly Lubricant (White Lithium Grease or Petroleum Jelly)
- Electrical Tape
- Sharp Knife or Razor Blade
- Tie Straps (Zip Ties)
- Trim Pad Tool (for pushpin removal)
- Fender Cover (2)
- Medium Strength Thread Locker – Loctite 242 (blue) or equivalent

# ROUSH

THE ART OF PERFORMANCE ENGINEERING

PREMIUM FUEL REQUIRED

## GLOSSARY OF TERMS

ACT	Air Charge Temperature Sensor (From the factory, this function is integrated into the MAF sensor. With this kit, a separate ACT sensor is installed into the intake manifold)
CMCV	Charge Motion Control Valve (Located on the back of the base intake manifold. This feature is not used with the ROUSHcharger)
ETC	Electronic Throttle Control
IPTS	Injection Pressure and Temperature Sensor
MAFS	Mass Air Flow Sensor
PCM	Powertrain Control Module (a.k.a. ECM, ECU, PCU, EEC)
PCV	Positive Crankcase Ventilation
SCBP	Supercharger Control Bypass Solenoid (A 3-way electronic vacuum control solenoid that allows the PCM to control the ROUSHcharger bypass to reduce heat buildup and noise during low throttle operation)
TPS	Throttle Position Sensor
VMV	Vapor Management Valve (Located on driver side strut tower)
Breakout Point	A place in an electrical harness where the wiring for an individual component leaves (breaks out of) the main harness to attach to an individual component.

## INFORMATION ABOUT THE SUPERCHARGER BYPASS OPERATION

There is a great deal of misinformation about the function of supercharger bypass systems. The supercharger is a positive-displacement pump; that is, so long as it is rotating, it is always pumping air. During low demand or high vacuum operation (i.e. idle, deceleration, and light throttle cruise), the pumping action is undesirable as it creates unwanted heat and noise. The bypass circuit, when open, prevents any pressure buildup across the supercharger and allows air to circulate through the rotors, allowing the supercharger to "idle" freely during these conditions. This results in reduced noise, and by reducing heat buildup in the intake, significantly improves street and strip performance. As throttle demand increases, the bypass circuit is closed, resulting in full performance from the supercharger. The bypass circuit is never used to limit or control boost during full-throttle operation and defeating or altering the bypass function will not result in improved performance in any condition, and will result in poor drivability.



## **LIMIT OF LIABILITY STATEMENT**

The information contained in this publication was accurate and in effect at the time the publication was approved for printing and is subject to change without notice or liability. Roush Performance Products (RPP) reserves the right to revise the information presented herein or to discontinue the production of parts described at any time.

## **SAFETY PRECAUTIONS**

**STOP! CAREFULLY READ THE IMPORTANT SAFETY PRECAUTIONS AND WARNINGS BEFORE PROCEEDING WITH THE INSTALLATION!**

Appropriate disassembly, assembly methods and procedures are essential to ensure the personal safety of the individual performing the kit installation. Improper installation due to the failure to correctly follow these instructions could cause personal injury or death. Read each step of the installation manual carefully before starting the installation.

1. Always wear safety glasses for eye protection.
2. Place the ignition switch in the OFF position.
3. Always apply the parking brake when working on the vehicle.
4. Block the front and rear tire surfaces to prevent unexpected vehicle movement.
5. Operate the engine only in well-ventilated areas to avoid exposure to carbon monoxide.
6. Do not smoke or use flammable items near or around the fuel system.
7. Use chemicals and cleaners only in well-ventilated areas.
8. Batteries can produce explosive hydrogen gas which can cause personal injury. Do not allow flames, sparks or flammable sources to come near the battery.
9. Keep hands and any other objects away from the radiator fan blades.
10. Keep yourself and your clothing away from moving parts when the engine is running.
11. Do not wear loose clothing or jewelry that can be caught in rotating or moving parts.

### **WORK SAFELY!**

Perform this installation on a good clean level surface for maximum safety and with the engine turned off.

# ROUSH

THE **ART** OF PERFORMANCE ENGINEERING

PREMIUM FUEL REQUIRED

## SECTION A – DISASSEMBLY

The following section will guide you through the disassembly of the stock components. Special care should be taken to label fasteners and parts that are taken off during this procedure since many will be reused:

1. Cover both fenders with fender covers to protect the vehicle finish.
2. Release the fuel system pressure (**NOTE:** The following procedure is taken directly from the Ford Service Manual).

 **WARNING:** Fuel in the fuel system remains under high pressure even when the engine is not running. Before working on or disconnecting any of the fuel lines or fuel system components, the fuel system pressure must be relieved. Failure to do so can result in personal injury.

 **WARNING:** Do not smoke or carry lighted tobacco or open flame of any type when working on or near any fuel-related components. Highly flammable mixtures are always present and can be ignited, resulting in personal injury.

- a. Remove the fuel pump module fuse.

**NOTE:** The fuel pump module fuse is located in the underhood fuse box, location F41.

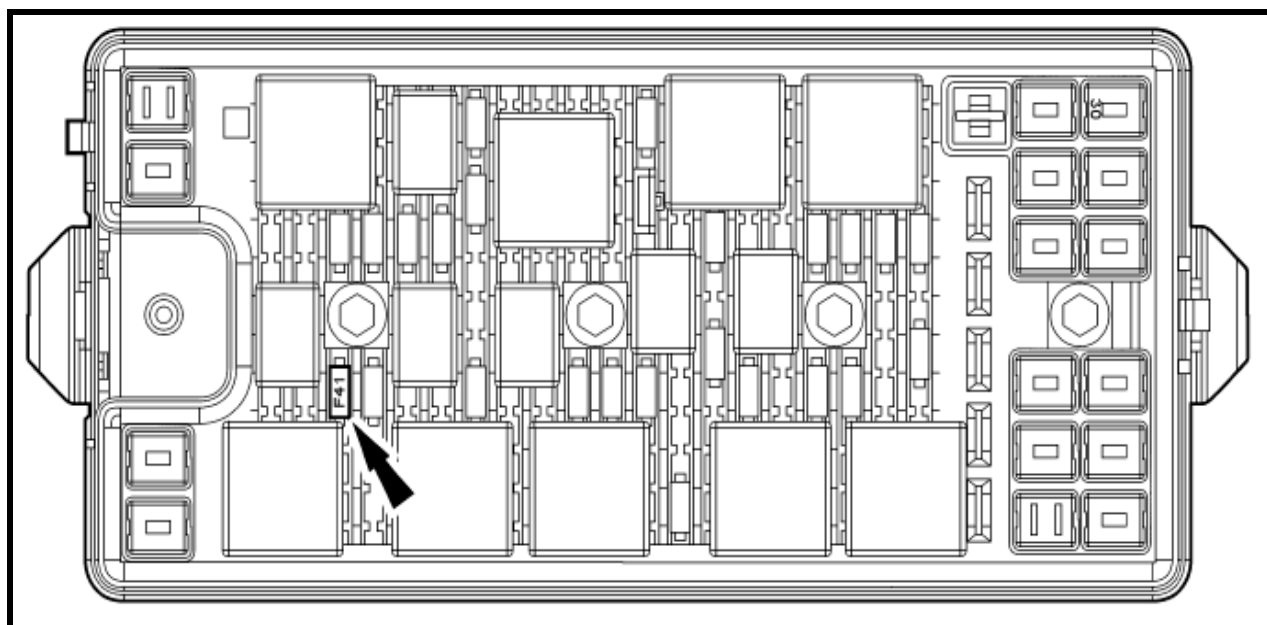

# ROUSH

THE **ART** OF PERFORMANCE ENGINEERING

PREMIUM FUEL REQUIRED

- b. Start the engine and allow it to idle until it stalls.
  - c. After the engine stalls, crank the engine for approximately 10 seconds to make sure the fuel injector supply manifold pressure has been released.
  - d. Turn the ignition switch to the OFF position.
  - e. Reinstall the fuse that was removed in step a.
3. Using an 8mm wrench, disconnect the (-) negative & (+) positive connections to the battery. Remove the battery hold down bolt using an 8mm socket wrench. Remove the hold down & battery. With an 8mm socket wrench, remove the 3 bolts holding the battery tray to the vehicle. Remove the battery tray.

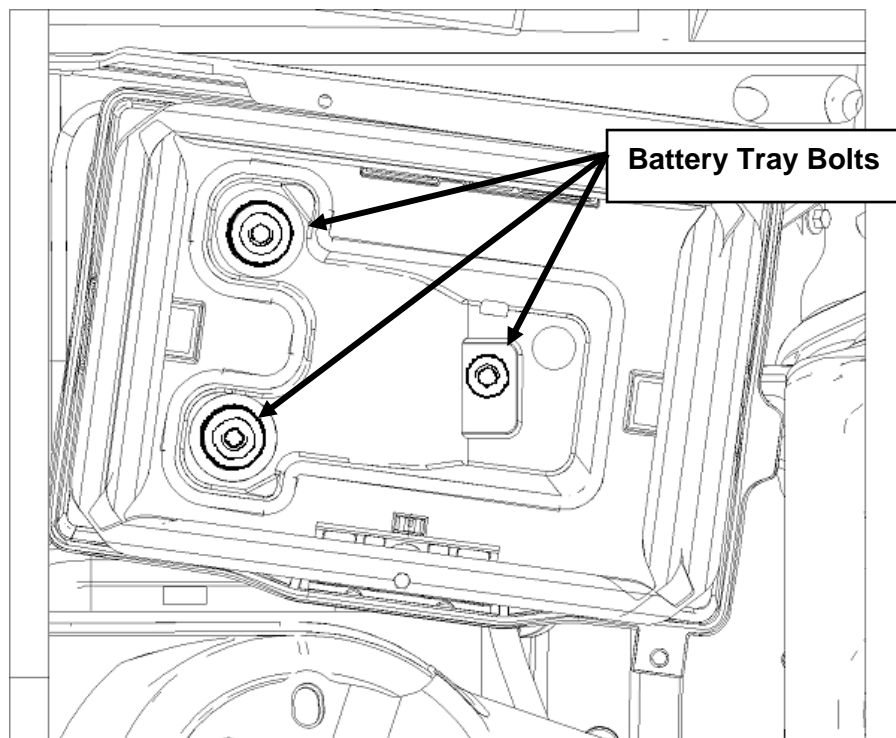

# ROUSH

THE **ART** OF PERFORMANCE ENGINEERING

PREMIUM FUEL REQUIRED

4. Disconnect the 3 PCM (Powertrain Control Module) connectors by lifting the grey levers over the connector back shell and lifting the connectors from their sockets. Remove the PCM by removing two 10mm bolts and pulling the PCM forward and lifting out of the engine compartment. Follow the instructions on the next page as soon as possible to help minimize the amount of time you are without a PCM.

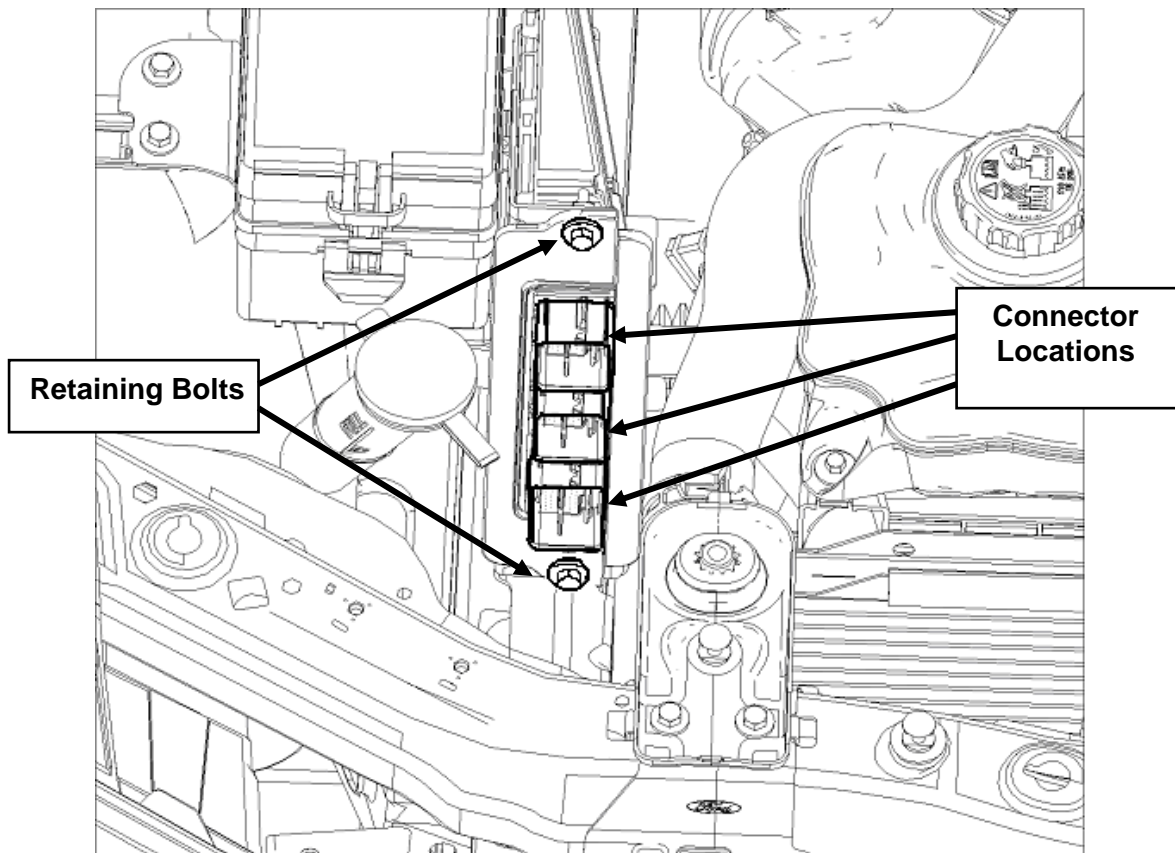

**Important:** Be sure to write your VIN number and phone number (in case we need to contact you for additional vehicle information) on the PCM using a permanent marker.

# ROUSH

THE **ART** OF PERFORMANCE ENGINEERING

PREMIUM FUEL REQUIRED

## INSTRUCTIONS FOR RETURNING THE PCM TO ROUSH FOR CALIBRATION

Outlined below are the instructions for returning your stock powertrain control module (PCM) to Roush Performance Products so we can install our calibration to make the engine run properly with the new components. **Please complete the "Warranty Registration Card" and include it, along with the PCM, in the prepaid shipping box.** The prepaid shipping box is set-up for next day delivery to us. Once we receive your PCM, we will reprogram and return it back to you the same day for next-day delivery. **Operating your engine without our calibration will result in engine damage or failure and will void all warranty.**

**Note: It is important to reinstall the PCM in the vehicle it came from to prevent setting a trouble code and having to relearn the anti-theft code which can only be performed using specialized Ford Service Bay tools.**

- If you haven't already done so, write your vehicle identification number (VIN) and phone number on the PCM using a permanent marker.
- Remove the bubble wrap from inside the supplied shipping box and wrap it around the PCM to help prevent it from being damaged during shipping.
- Place the wrapped PCM in the shipping box (R07140023).
- **Complete the "Warranty Registration Card" (131019A505) and include it in the shipping box along with the PCM.**
- Fill in your name and address in the **FROM** area of the shipping label that is located inside the box. Follow the instructions on the box for sealing it shut.
- Peel the right label off and attach to the box where indicated.
- Retain the left side label for your records.
- Schedule a FEDEX **Package Pick-up** by calling **1-800-463-3339** and select **OPTION 0** to speak directly to an agent. DO NOT use the automated option to schedule a pick up.
- Inform the agent you have a **Prepaid FEDEX billable stamp package** and you need a pick-up.
- If there are any issues with the shipping box we supply and you want to ship the PCM to us another way, the address for the PCM re-flash only is: Roush Powertrain Development, Building 57 – **attn: PCM Flash, 777 Republic Drive, Allen Park, MI 48101**



## 2005-06 Mustang ROUSHCharger Kit

Customer Name: \_\_\_\_\_ Contact Number: \_\_\_\_\_

VIN: \_\_\_\_\_

# ROUSH

THE ART OF PERFORMANCE ENGINEERING

PREMIUM FUEL REQUIRED

5. With the engine cool, remove the cap on the engine coolant degas bottle and drain the coolant using the petcock located on the lower passenger side of the radiator.

TIP: Connect 3/8" hose to the drain fitting next to the petcock and run into a clean drain pan or bottle. Use a 3/4" wrench to open petcock and allow coolant to drain out of the fitting.

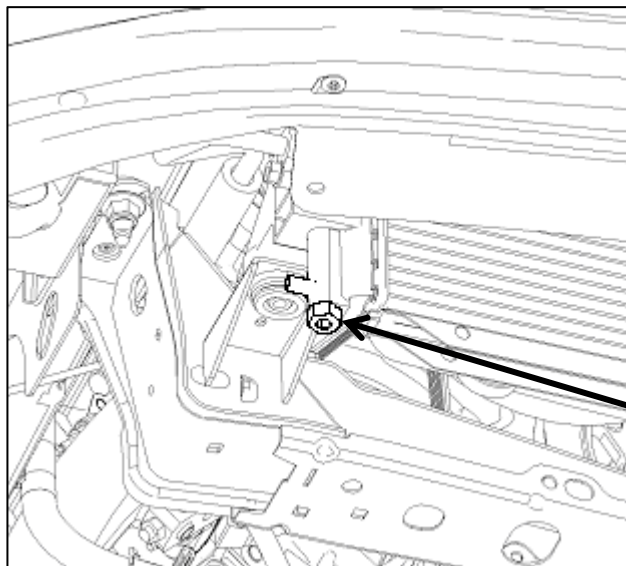

Drain Petcock

6. Disconnect the PCV vent tube from the right-hand cam cover and clean air tube. Using an 8mm nut driver, loosen the 2 clamps at either end of the clean air tube. Remove the clean air tube from the throttle body and airbox.

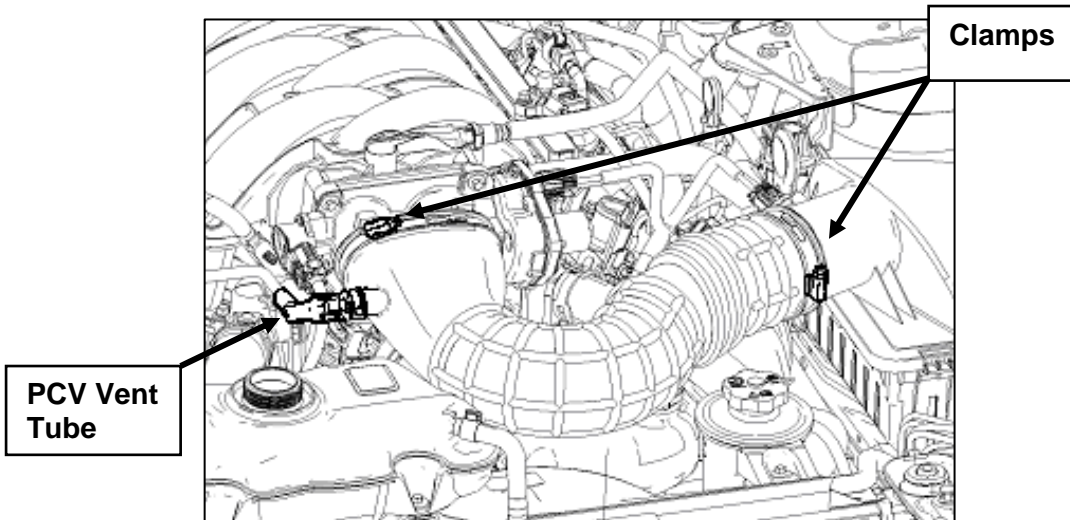

PCV Vent Tube

Clamps



# ROUSH

THE ART OF PERFORMANCE ENGINEERING

PREMIUM FUEL REQUIRED

7. Remove the MAF (mass air flow) connector by pulling the red locking tab back and pressing the black release tab. With a 10mm socket wrench, remove the airbox hold down bolt. Firmly grasp the airbox and pull up to remove it from the vehicle.

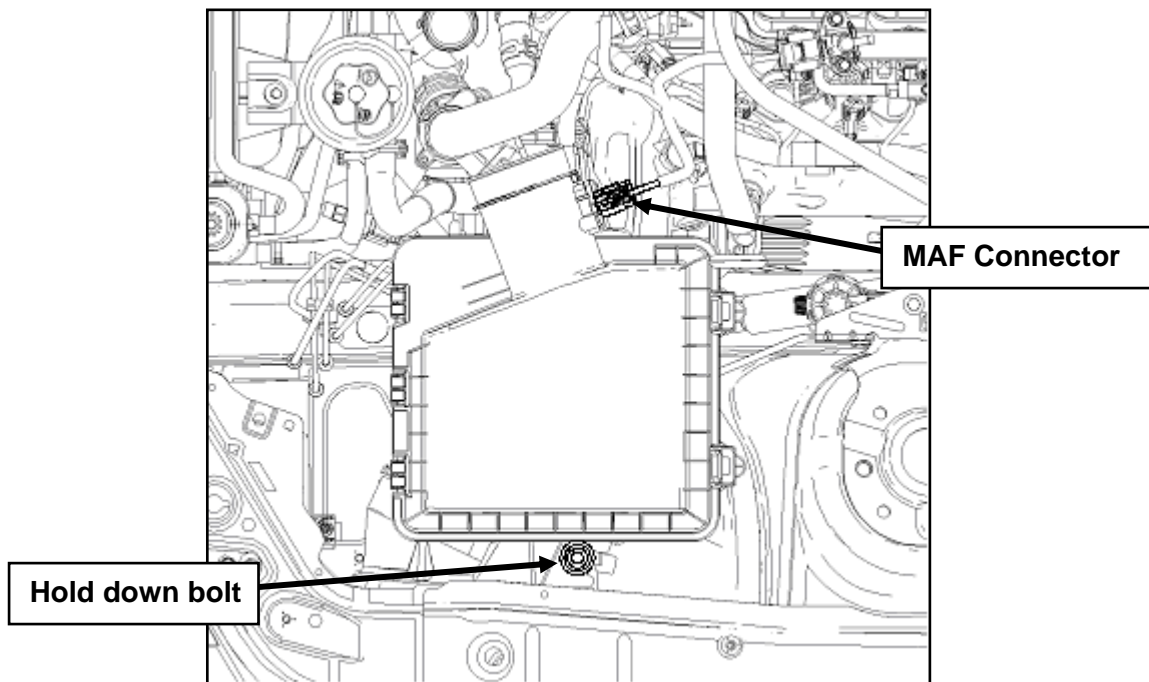

8. Disconnect ETC (electronic throttle control) & TPS (throttle position sensor) connectors from the throttle body (Pull the red locking tab back; press the black release tab to disengage the lock). Remove the throttle body using an 8mm socket wrench (for the top two bolts) and a 10mm socket wrench (for the bottom two nuts). Remove the throttle body and the throttle body gasket from the intake manifold. Wipe the seal clean and dry and install it into the machined groove in the new throttle body spacer (P/N R07060041).

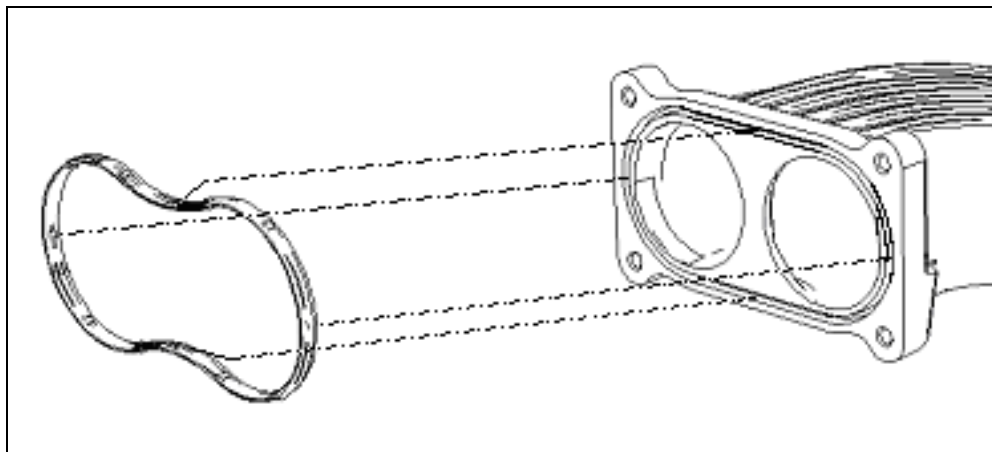

# ROUSH

THE **ART** OF PERFORMANCE ENGINEERING

PREMIUM FUEL REQUIRED

9. Remove the PCV line from the intake manifold and left-hand cam cover. Remove the VMV line from the intake manifold and position out of the way. Remove the vacuum line and electrical connector from the IPTS on the fuel rail and save for reuse. Remove the black safety clip from the fuel line connection. Place rags under the fuel rail, using a 5/8" fuel line tool (wrap additional rags around the tool) and disconnect the fuel line from the fuel rail. There will be some release of pressurized fuel, so be careful and proceed slowly.

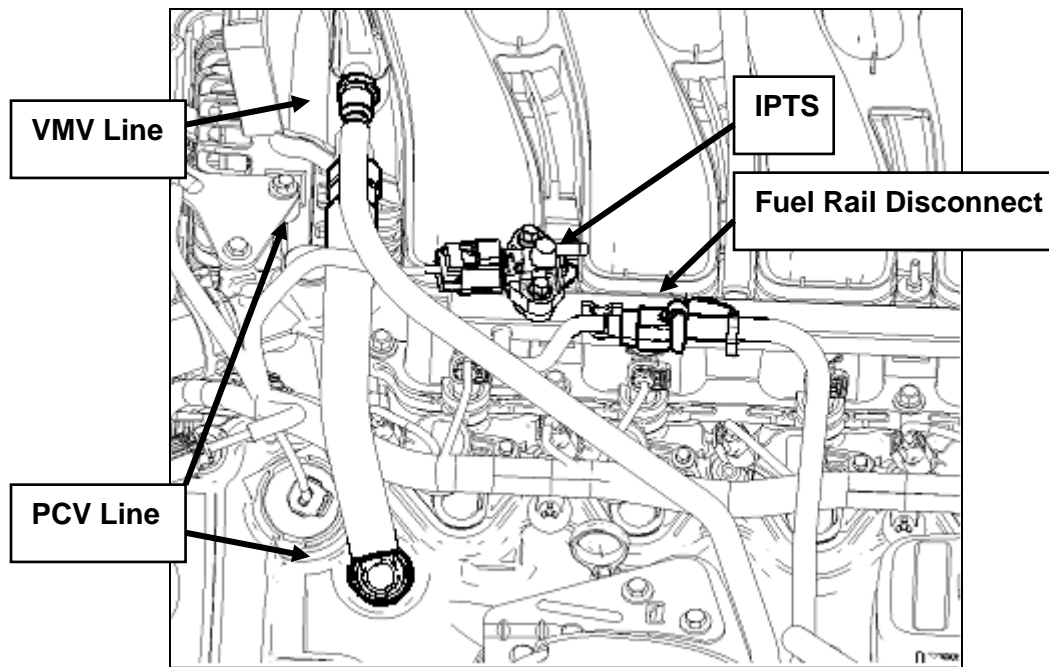

10. Disconnect the alternator harness from the positive battery terminal and remove the harness clips from the fuel rail studs.

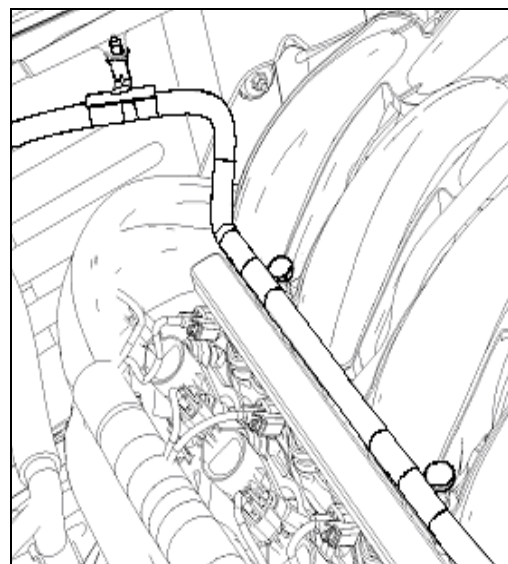
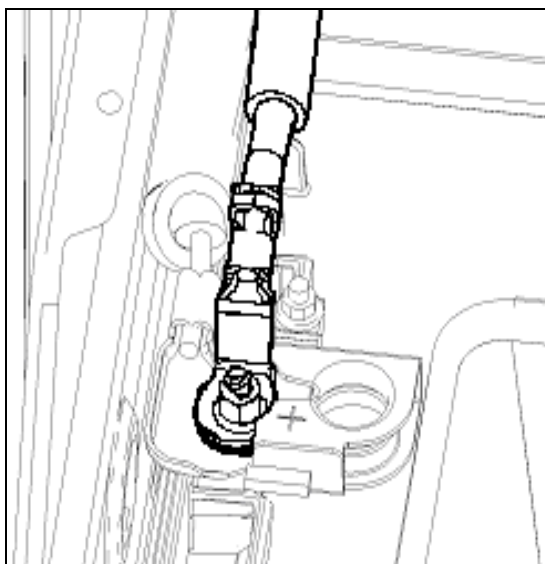

# ROUSH

THE **ART** OF PERFORMANCE ENGINEERING

PREMIUM FUEL REQUIRED

11. Disconnect the wiring connectors from the fuel injectors (8). Remove the four 8mm stud bolts holding the fuel rail to the intake manifold and remove the fuel rail assembly with injectors. There may be some additional fuel leakage around the injectors. Clean all excess fuel before proceeding. Remove injectors and retainer clips from the fuel rail. Save the retainer clips for reuse.

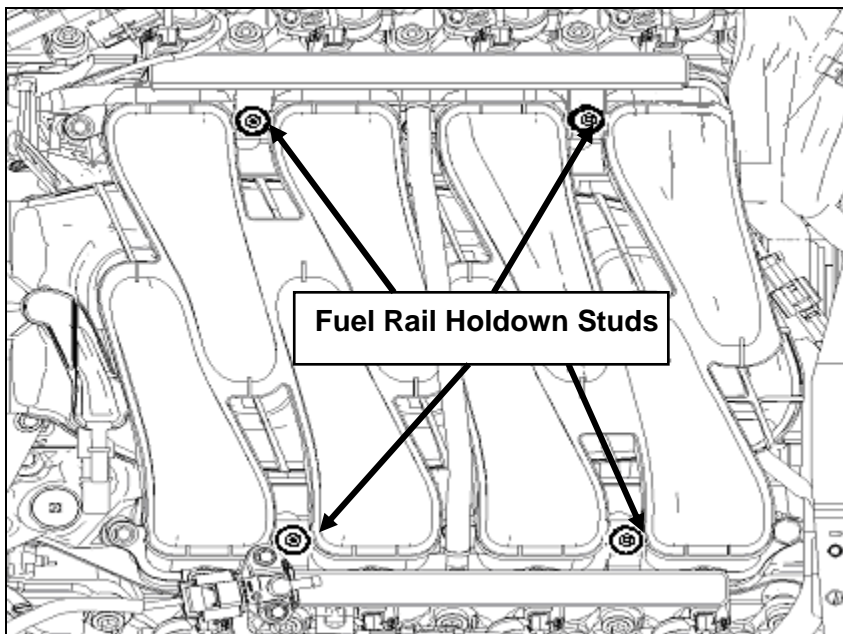

12. Disconnect the CMCV connector located in the center rear of the intake manifold. Remove the brake booster vacuum line from the intake manifold. Pull the wiring harness off of the stud bolt on the driver side rear of intake manifold. Remove the ten fasteners which used to bolt the intake manifold to the cylinder heads. Save the rear stud for reuse. Remove the intake manifold. Use tape or equivalent to cover the cylinder head ports to prevent engine contamination.

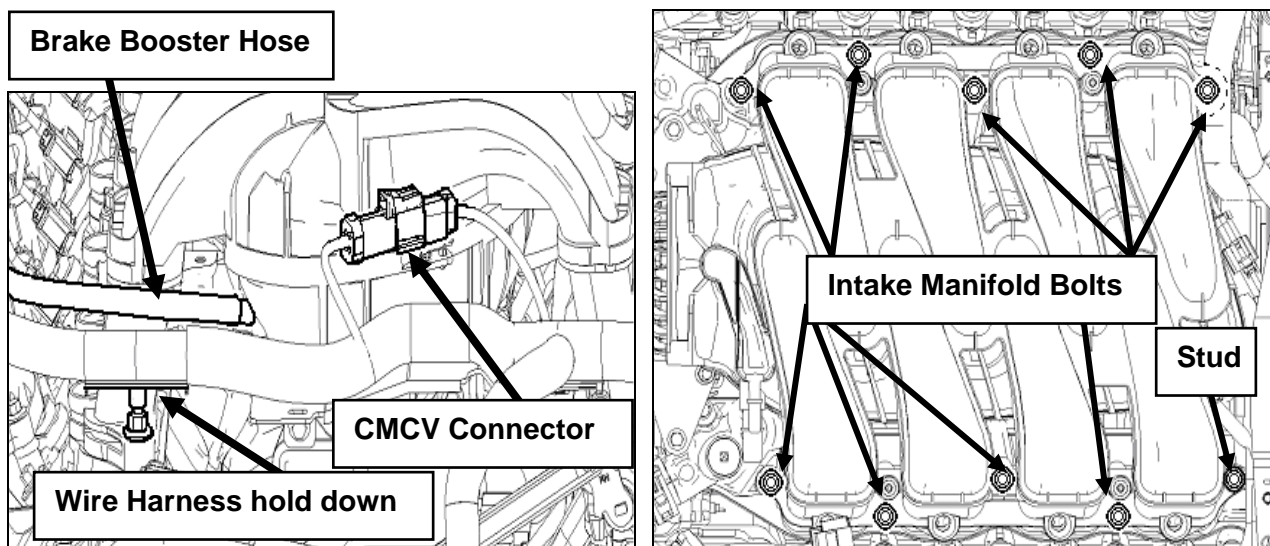

# ROUSH

THE **ART** OF PERFORMANCE ENGINEERING

PREMIUM FUEL REQUIRED

13. Release the accessory drive belt by rotating the tensioner clockwise with a ½ " breaker bar or ratchet and slip the belt off the water pump pulley and remove the belt completely. Disconnect the regulator connector and the battery cable from the alternator. Using a 10mm socket wrench, remove the four upper support bracket bolts. Remove the two 15mm alternator nuts and remove the alternator.

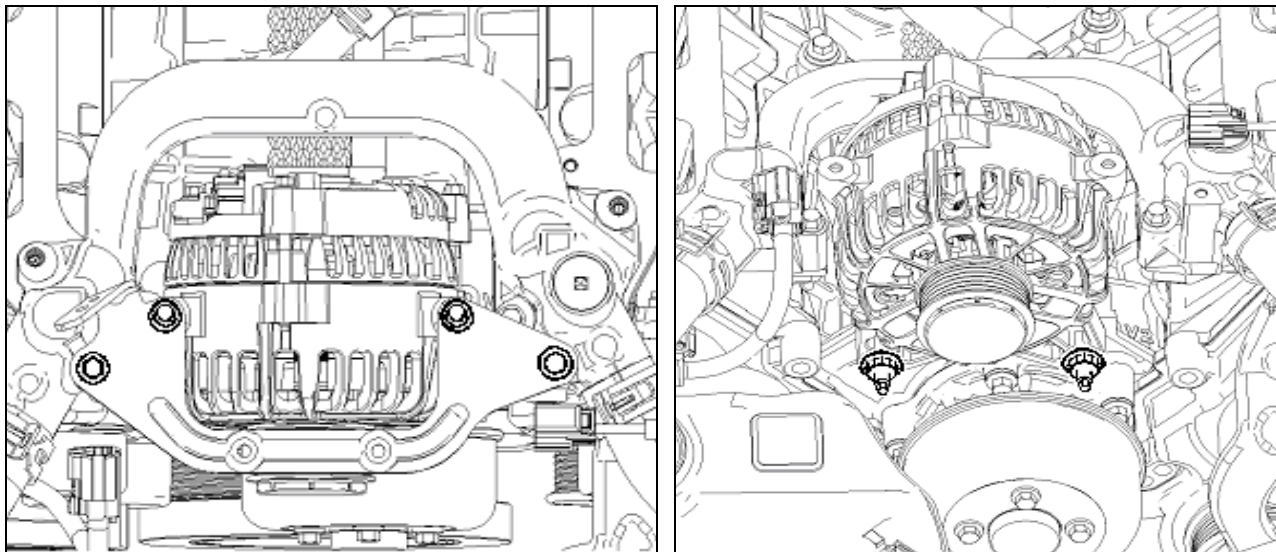

14. Remove the factory coolant fill plug from the water crossover using a ¼" ratchet. Remove the upper radiator hose from the front of the water crossover (do not remove from the radiator). Completely remove the bypass circuit radiator hose. On the back side of the water crossover, disconnect the heater hose. Remove the water crossover using a 10mm socket wrench.

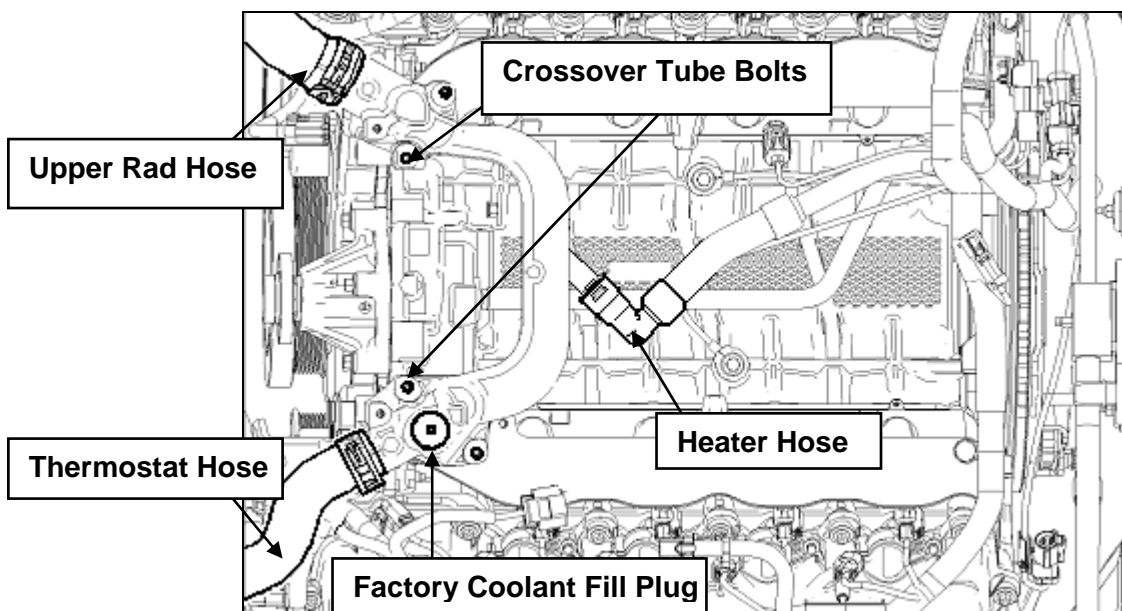

# ROUSH

THE **ART** OF PERFORMANCE ENGINEERING

PREMIUM FUEL REQUIRED

15. Disconnect the rubber portion of the heater hoses from the metal tubes at the rear of the right-hand cylinder head. Remove the heater tube assembly from the engine by removing the stud on the back side of the passenger cylinder head and sliding off the water pump fitting in the block.

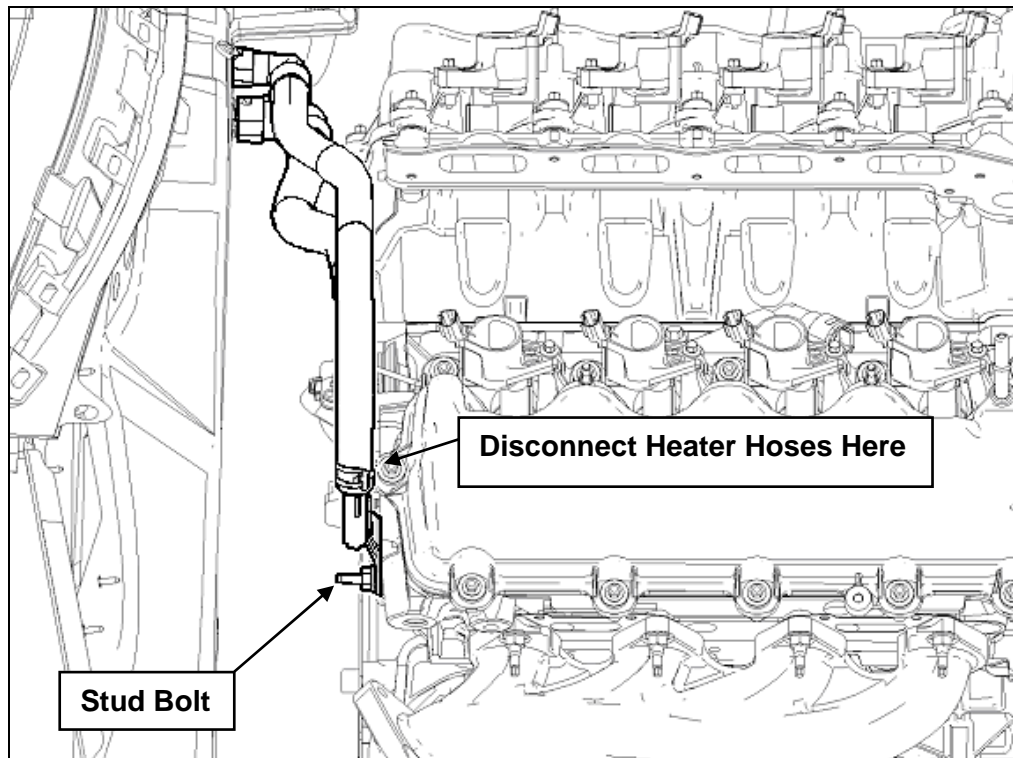

# ROUSH

THE **ART** OF PERFORMANCE ENGINEERING

PREMIUM FUEL REQUIRED

## SECTION B – MODIFICATIONS

The following section will guide you through the required modifications of existing components and build up of the assemblies used to complete the installation. With the exception of the wiring modifications and intercooler pump bracket mounting, all of this work can be performed away from the vehicle.

### Alternator Modification

1. In order for the alternator to be installed in its new location, two of the original mounting ears must be removed. Using a band saw or similar cutting tool, remove the mounting ears shown. Be careful to avoid getting debris inside of the alternator when removing these features.

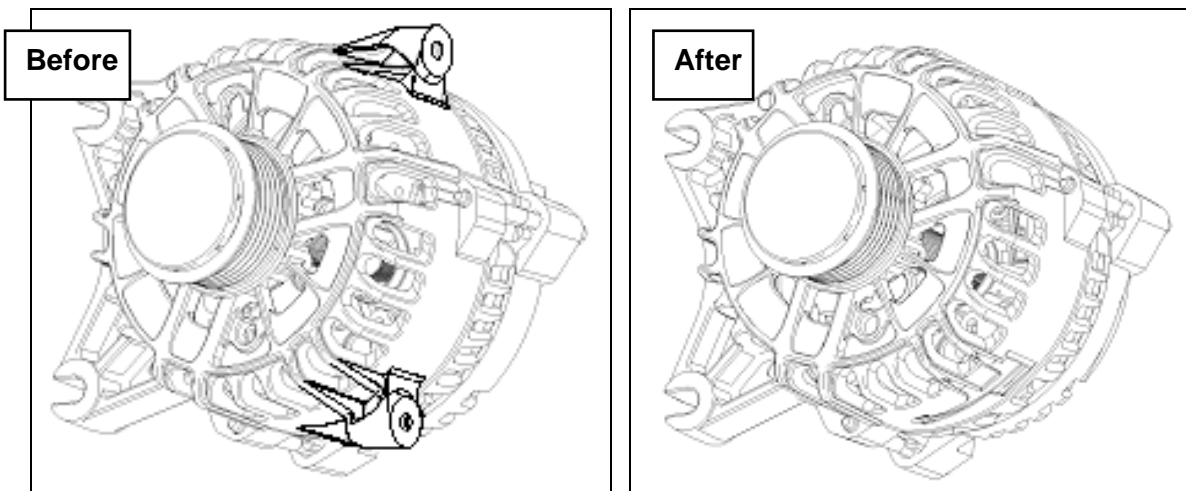

# ROUSH

THE **ART** OF PERFORMANCE ENGINEERING

PREMIUM FUEL REQUIRED

## Coolant Hose Hanger Modification

1. Locate the coolant hose hanger on the front of the engine and remove.

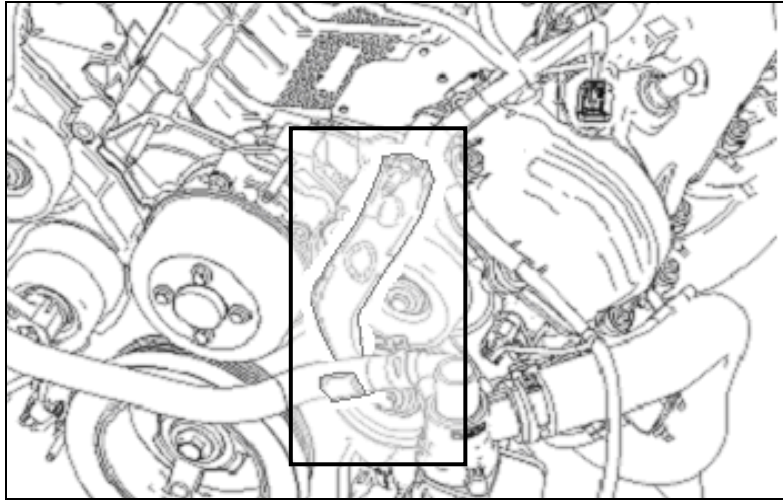

2. Remove the highlighted section of the bracket as illustrated below. Doing so is necessary to provide clearance to the new alternator mounting bracket.

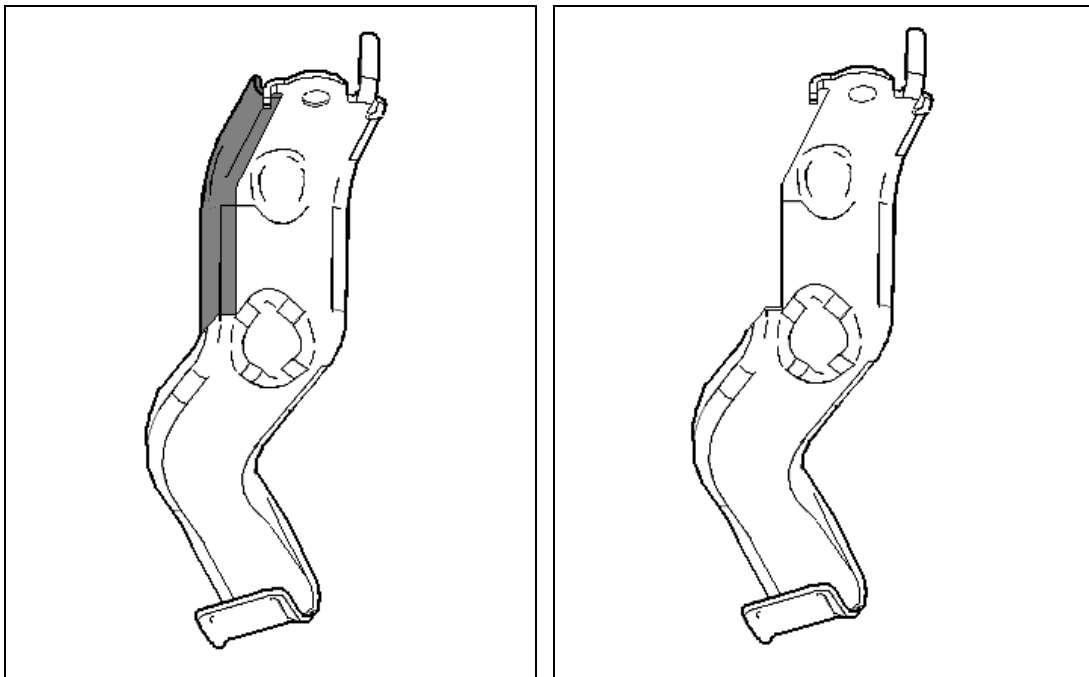

# ROUSH

THE ART OF PERFORMANCE ENGINEERING

PREMIUM FUEL REQUIRED

## Airbox Modification

1. Remove the MAF sensor from the stock airbox cover and install into the new clean air tube (R07060026) using the two #8-32 screws and #8 washers provided in the induction kit. Install the rubber grommet and the SAE-style PCV fitting into the clean air tube. Install the tube support bracket (R07060066) in Hardware Kit B with the ¼-20x3/4" bolts and washers in the Induction Kit.

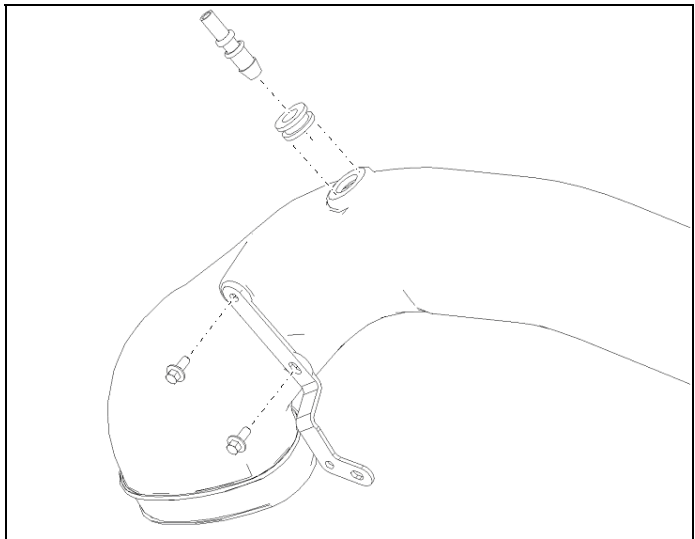
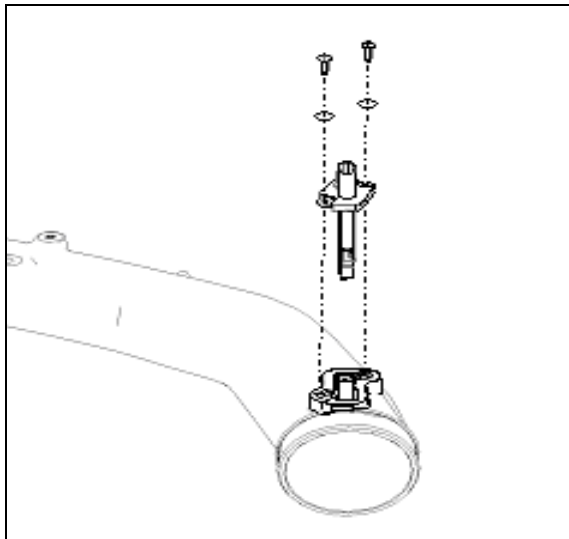

2. Using the take out screws from the MAF, install the MAF block off plate w/gasket (R07060065) from Hardware Kit B onto the cover of the airbox. Torque the screws to 1.8 – 2.5 Nm.

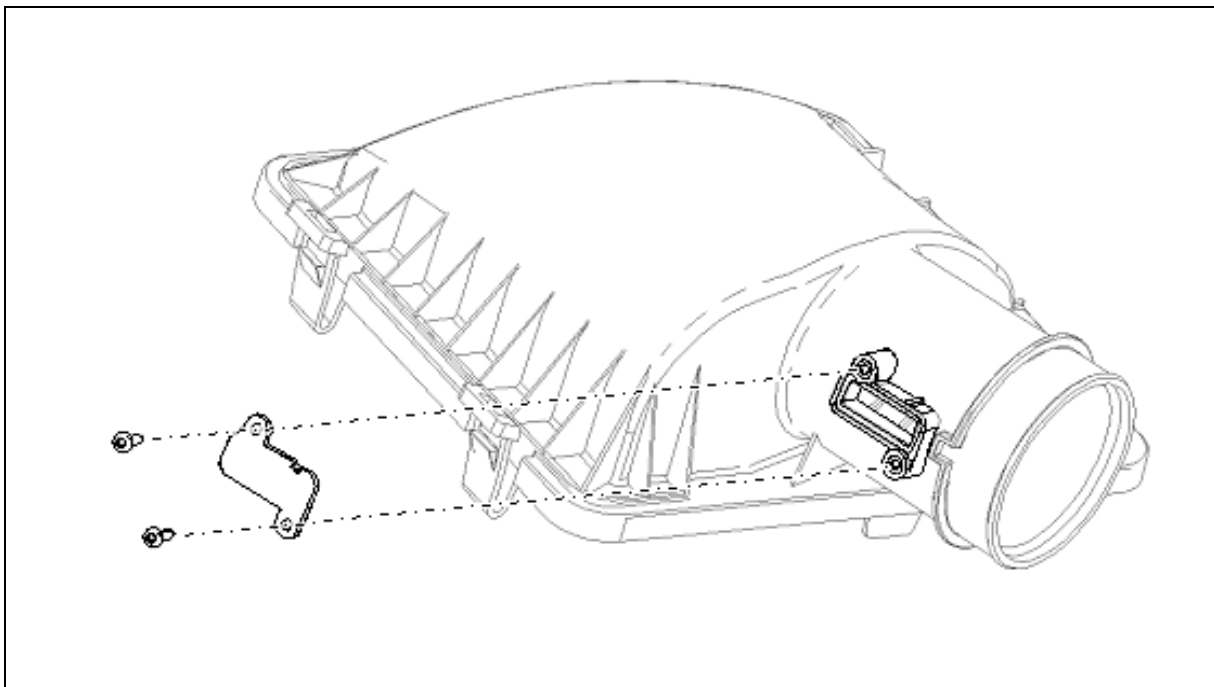



# ROUSH

THE ART OF PERFORMANCE ENGINEERING

PREMIUM FUEL REQUIRED

3. Remove the dirty air inlet from the airbox. Install the supplied larger cross-section dirty air inlet (R07060061). It may be necessary to clip off the top of the hook to ease installation. Be careful not to crack or damage the new dirty air inlet during installation.

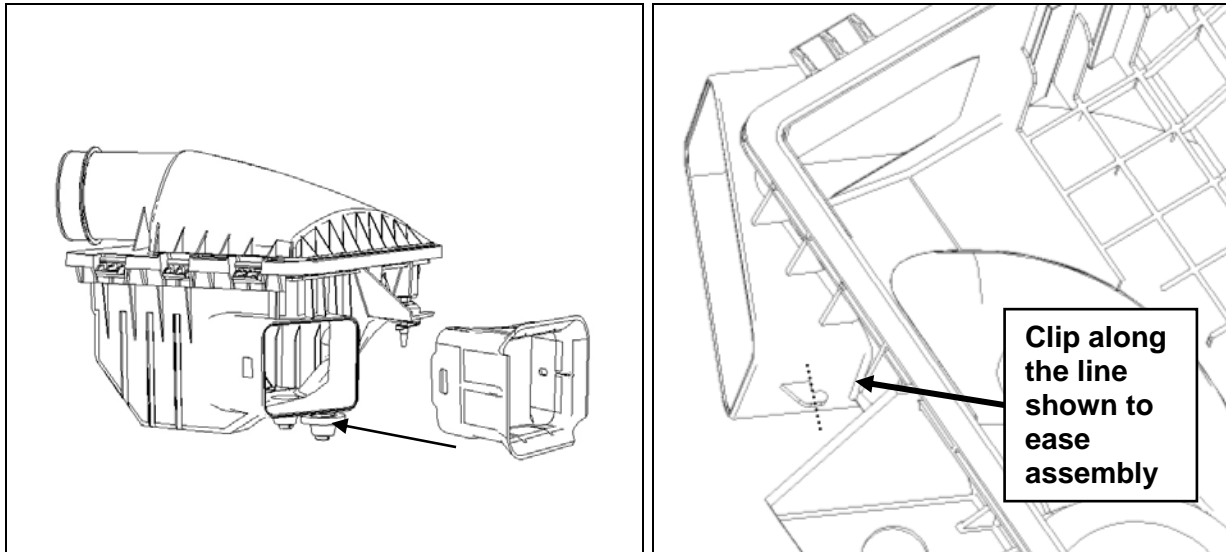

4. Remove the airbox cover and stock air filter. Thoroughly clean the inside of the airbox cover with brake clean or equivalent. Spray brake clean on a shop rag and clean the bellmouth insert (R07060062) on the rear face. Allow both parts to fully dry. Carefully install the bellmouth insert into the airbox cover using the supplied adhesive (Loctite 4210). Apply the adhesive generously to the bellmouth and apply pressure for approximately one hour to allow the glue to set up. Do not attempt to move the bellmouth once it sets as the adhesive takes a full twenty four hours to fully cure and must not be disturbed. Reinstall the air filter and reassemble the airbox.

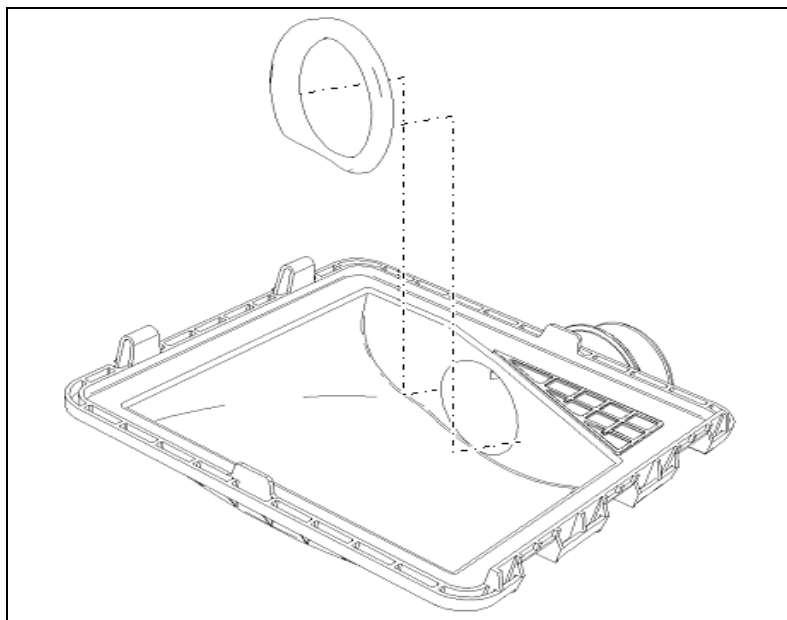

# ROUSH

THE **ART** OF PERFORMANCE ENGINEERING

PREMIUM FUEL REQUIRED

## Heater Tube Assembly Modification

1. The upper tube and hose on the heater tube assembly is not used (a new tube is supplied in the kit). Using a die grinder or air saw, cut the brackets that connect the two tubes together and deburr all sharp edges. Retain the lower tube which connects to the water pump and the mounting bracket for reinstallation.

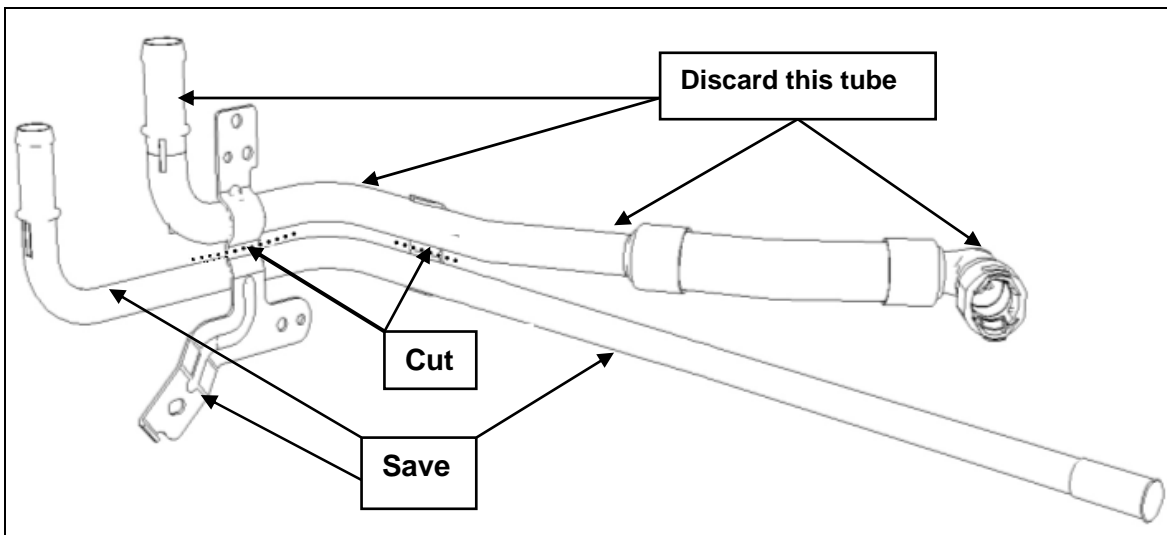

# ROUSH

THE **ART** OF PERFORMANCE ENGINEERING

PREMIUM FUEL REQUIRED

## Wiring Harness Modifications

The following details the modifications to the factory engine harness which are necessary to complete the installation of this kit. These modifications should be done without removing the harness from the engine as it will be easier to verify final locations of the break out points. Extreme care must be taken to insure that wiring and/or its insulation is not accidentally damaged while removing the convoluted tubing. All of the convoluted tubing and various clips that are removed while making these changes are intended to be reinstalled in the same place unless otherwise noted.

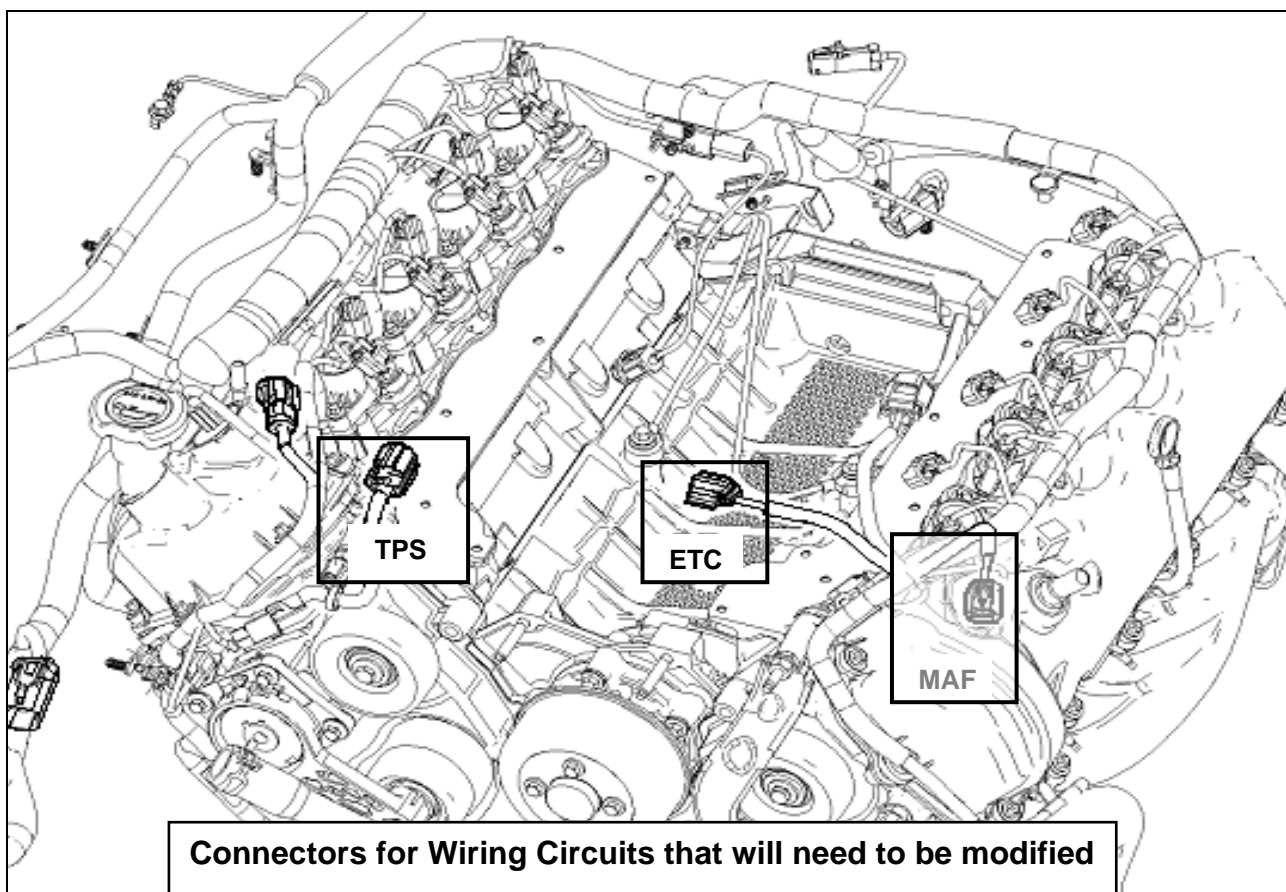

# ROUSH

THE **ART** OF PERFORMANCE ENGINEERING

PREMIUM FUEL REQUIRED

1. Make a note of the locations of the harness retaining clips and breakout points. With the harness still fastened to the engine with the factory retainers, carefully cut the tape off of the convoluted tubing and wiring harness on the drivers side of the engine (where the MAF & ETC branch out of the main harness) using a razor or utility knife. This area is highlighted in the following diagram. The convoluted tubing is split from the factory so follow the split. Lift the wiring out of the convoluted tubing without disturbing the factory retainers wherever possible. Expose all of the internal wiring from the MAF/ETC split all the way around to the rear of the passenger side cam cover and past the rear retainer.

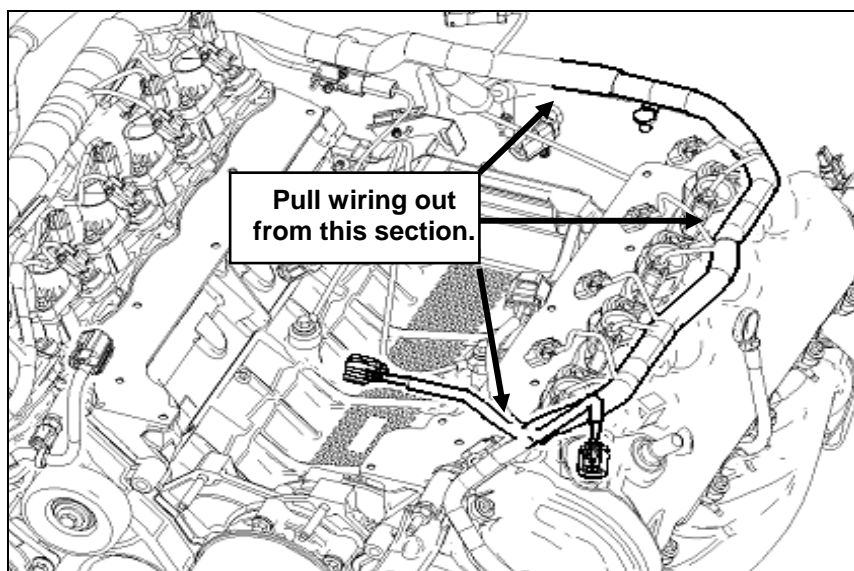

2. Locate the 6-wire MAF sensor connector. Looking into the face of the connector with the release tab positioned up, the first two wires in the connector (IAT) from the right are grey and grey w/ red tracer. Cut both of these wires approximately 5 to 6 inches from the back of the connector.

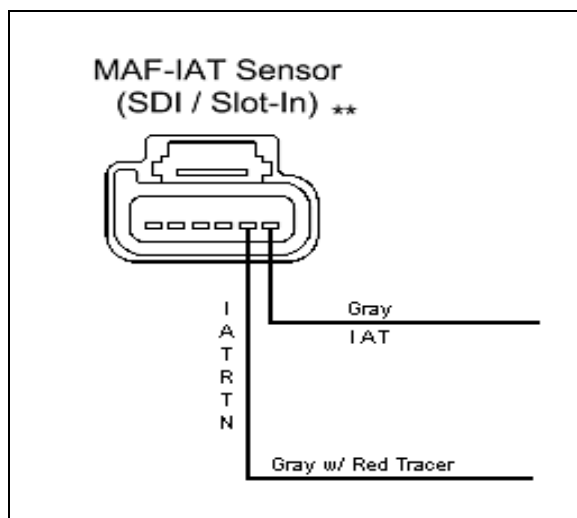
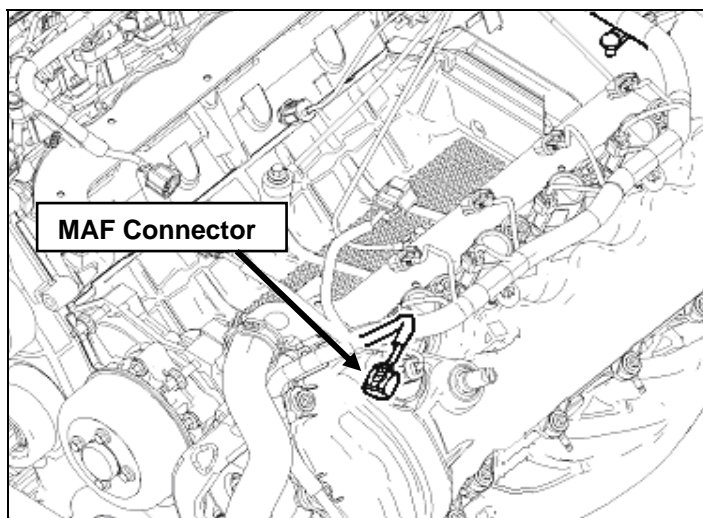

# ROUSH

THE ART OF PERFORMANCE ENGINEERING

PREMIUM FUEL REQUIRED

- Seal the connector side of both cut IAT wires with pieces of heat shrink provided in the ACT electrical jumper (R07080010) in Hardware Kit F. Place two pieces of heatshrink tubing halfway onto the ends of the wires to be sealed and heat with a heat gun until it stops shrinking and sealant flows out from the open end of the tubing.

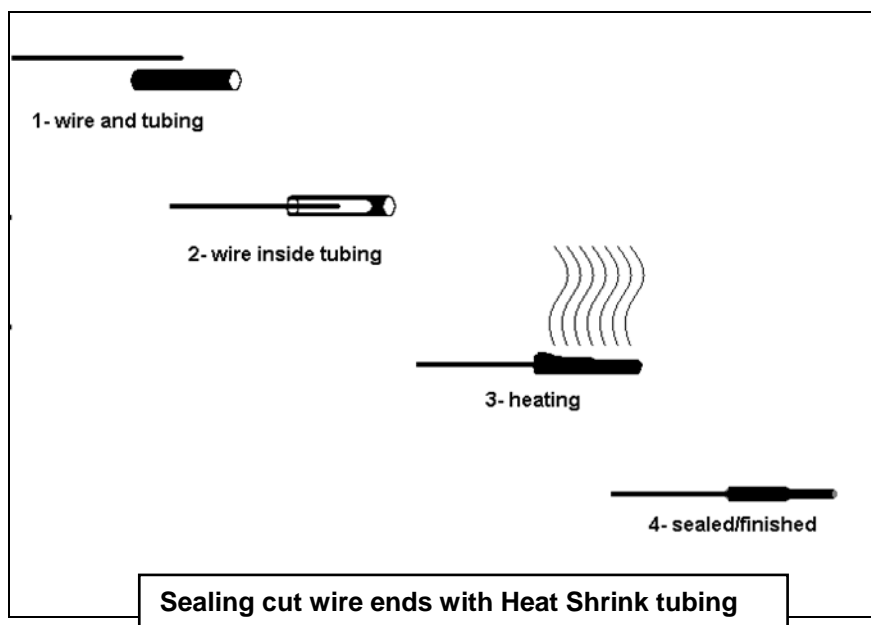

- Drag the 2 IAT wires out of the harness back from the MAF connector so that they breakout with the #7 Coil Connector. Strip a ¼ inch of insulation from the end of each wire. Slide a short length of heat shrink tubing over both wires. Now using the Electrical Jumper (ACT) from the kit (R07080010) lay the striped end of the Gray (IAT) wire into one side of the provided splice connector. From the Electrical Jumper (ACT) slide the ACT SIGNAL wire into the other side of the splice connector, and crimp using a W type crimping tool. Using a clean hot soldering iron, heat the wires (not the solder) in the splice connector until they are hot enough to melt the solder touched to them. Repeat the above for the IATRTRN – ACT GROUND. Slide the heat shrink tubing over the solder joints and heat to shrink with a heat gun. Wrap ACT harness with tape.

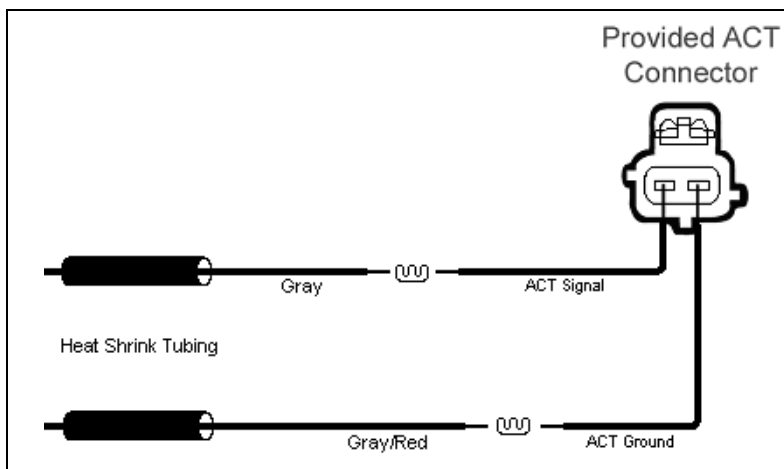
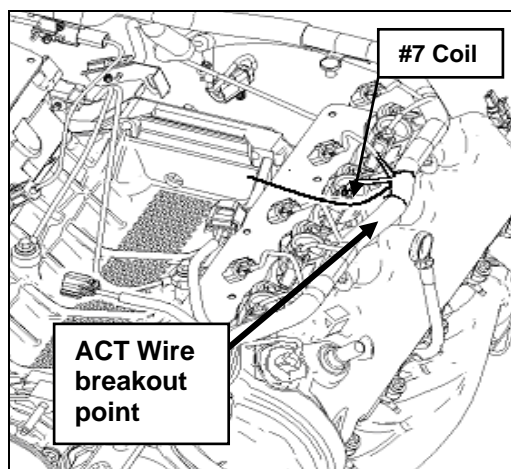

# ROUSH

THE ART OF PERFORMANCE ENGINEERING

PREMIUM FUEL REQUIRED

5. Drag the remaining MAF wiring/connector out of the harness and back toward the dash panel, moving the MAF breakout point to before the driver side rear intake harness retainer. Remove the driver side rear intake harness retainer and turn it backwards. Wrap MAF harness with tape. This will provide additional length to reach the new MAF position in the clean air tube.

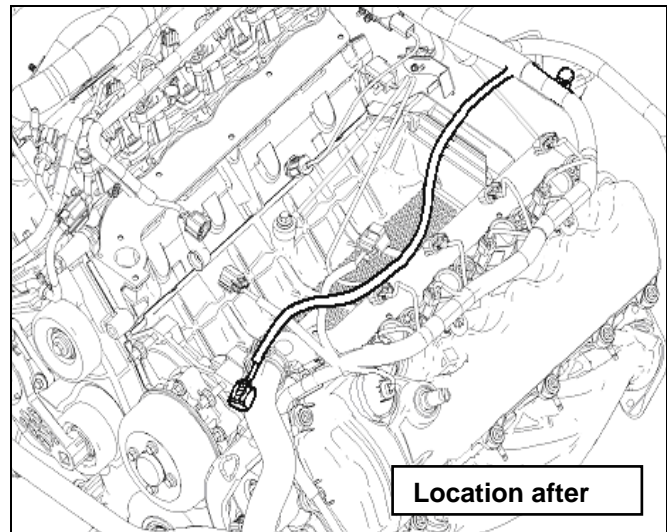
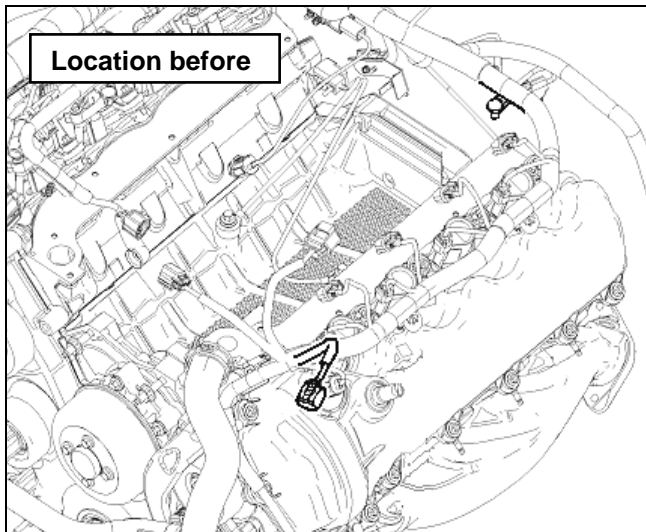

6. Pull the 2-wire ETC (electronic throttle control) wiring loose from the main harness and drag it back to the middle rear of the engine (same location as the MAF wiring in the previous step). At the middle rear of the engine, fold the ETC wiring back onto the still covered portion of the harness and route the ETC wiring with the harness over the breakout point near the #3 coil. Wrap the ETC harness to the existing harness with electrical tape.

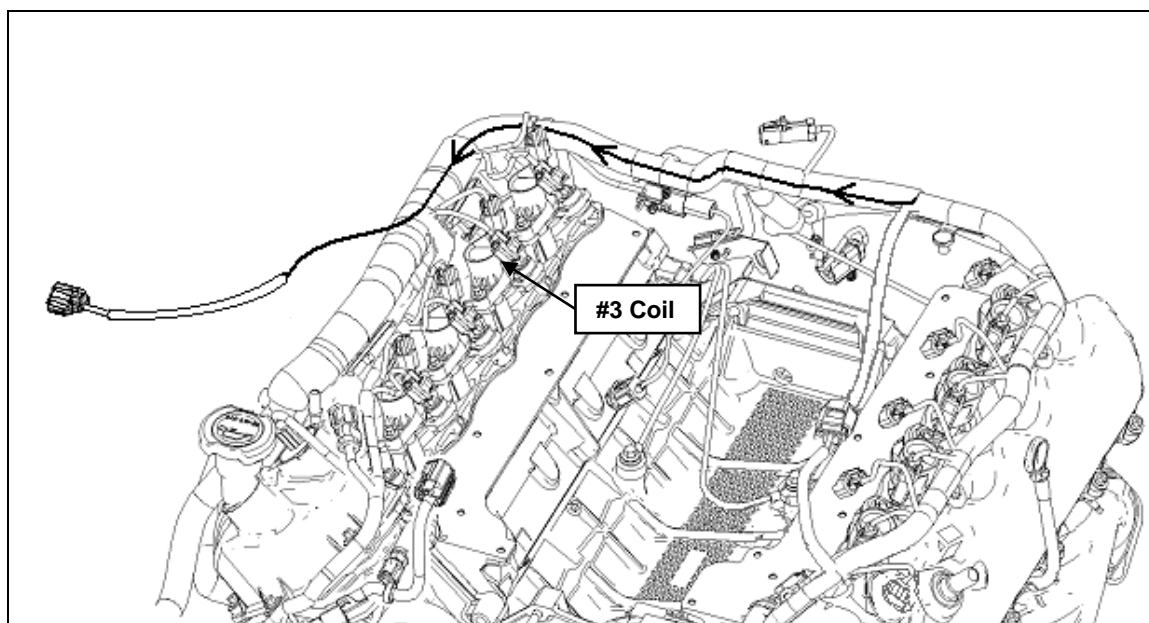

# ROUSH

THE **ART** OF PERFORMANCE ENGINEERING

PREMIUM FUEL REQUIRED

- Slide the driver side of the harness back into its convoluted tubing and re-tape.
- Locate the TPS (Throttle position sensor) connector and harness at the front of the passenger side valve cover. Remove the harness retainer for the timing cover bolt.

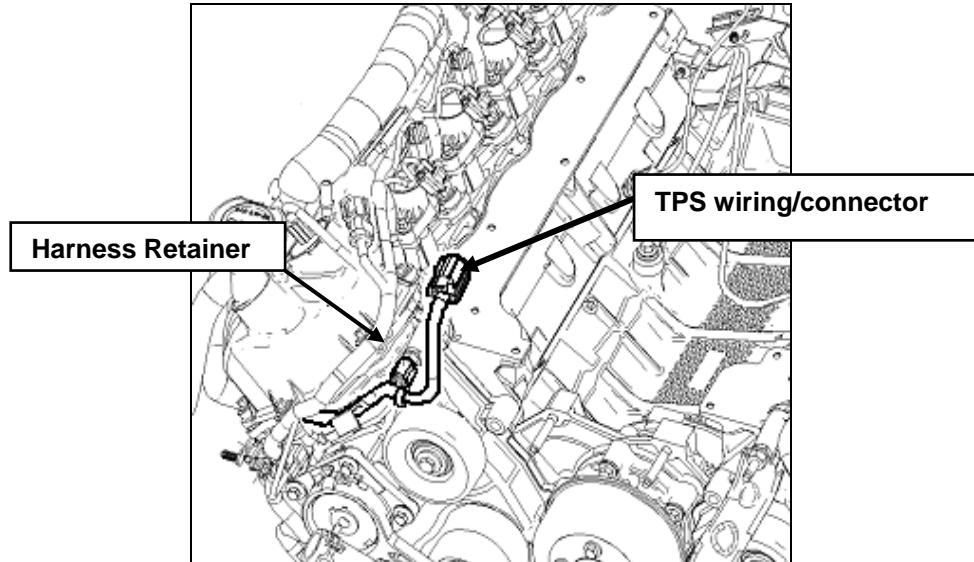

- Starting at the factory breakout point for the TPS, remove the electrical tape and convoluted tubing back to the #1 coil breakout point.

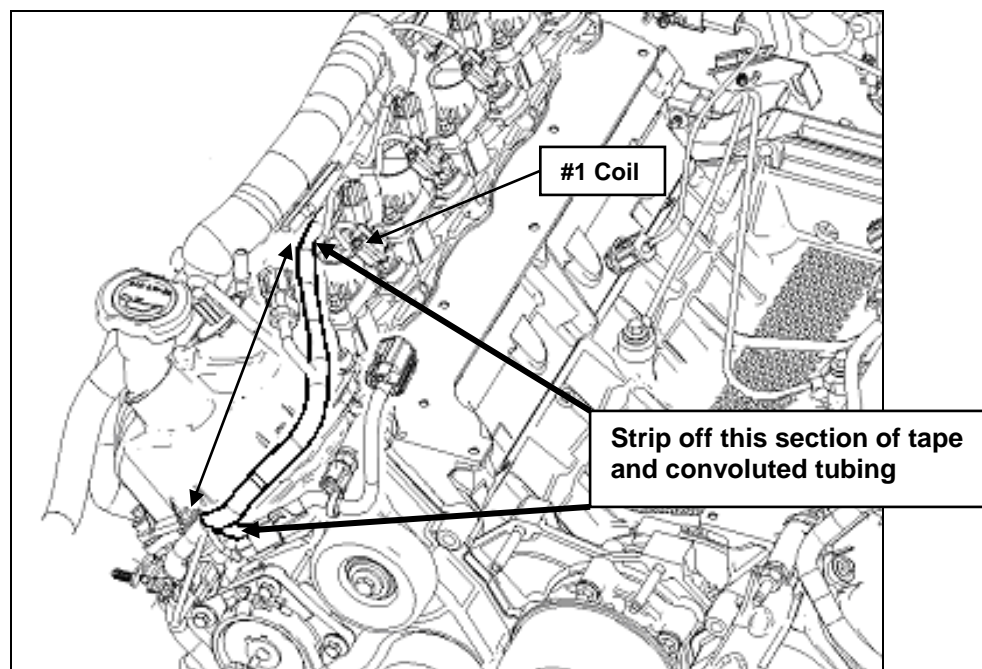

# ROUSH

THE **ART** OF PERFORMANCE ENGINEERING

PREMIUM FUEL REQUIRED

10. Pull the 4-wire TPS wiring/connector to near the #1 Coil breakout point.

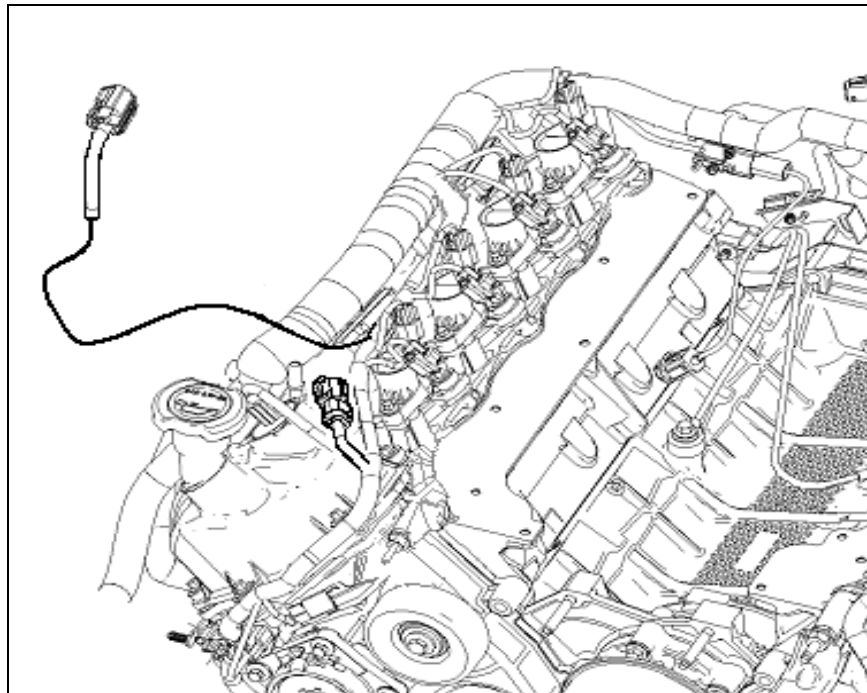

11. Fold back the TPS leads to the break from the main harness near the #3 coil and tape onto existing still taped harness. Reinstall any convoluted tubing and re-tape the rest of the harness.

12. Make sure there is at least 10" of free hanging lead for the TPS and ETC branches and wrap each with electrical tape.

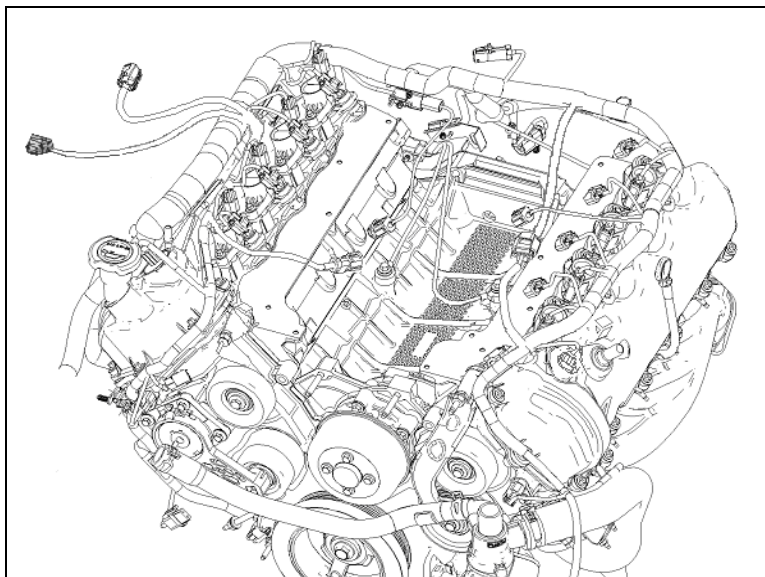



# ROUSH

THE **ART** OF PERFORMANCE ENGINEERING

PREMIUM FUEL REQUIRED

## SECTION C – SUBASSEMBLY

### Intake Manifold Build Up

1. Remove Fuel Charging Assembly (R07060083) from packaging.
2. Install the 3" long  $\frac{3}{4}$ " Heater Supply Hose and (1)  $\frac{3}{4}$ " Constant Tension Clamp (81) onto the heater Supply Tube (R07070014) from the Intercooler Hose Kit (R07010001). Place (1)  $\frac{3}{4}$ " CT clamp (81) over the intake manifold heater fitting. Install the Heater Supply Tube using (2) M6 x 1.0 x 13 mm bolts (N605771) from Hardware Kit C and torque to 8 – 12 Nm. Position the remaining loose hose clamp onto the hose and orient clamps as shown.

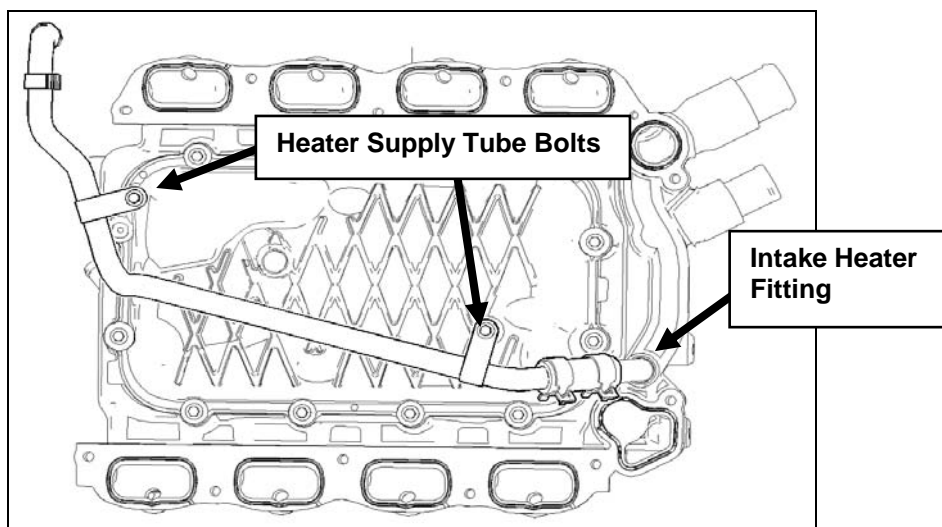

3. Attach PCV Bubbler Hose (R07040007) to the bubbler fitting and install PCV Bubbler Clamps to each end of the hose (all parts are from Intercooler Hose Kit).

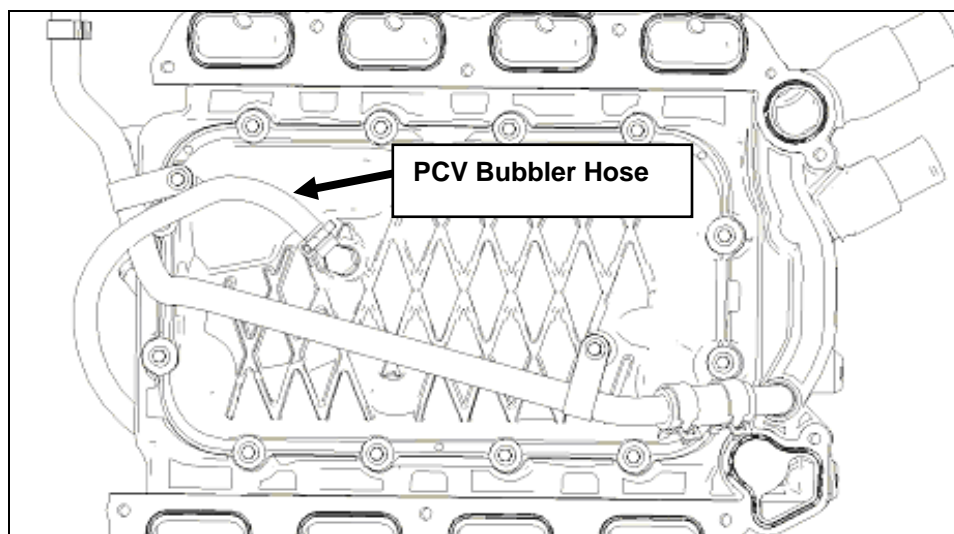

# ROUSH

THE ART OF PERFORMANCE ENGINEERING

PREMIUM FUEL REQUIRED

4. Inspect the Factory Coolant Fill Plug O-ring (removed from the stock water crossover). If the O-ring was damaged during removal you must replace the O-ring. Lube the O-ring and install the Factory Coolant Fill Plug into the new upper intake manifold. Torque to 12 – 18 Nm.

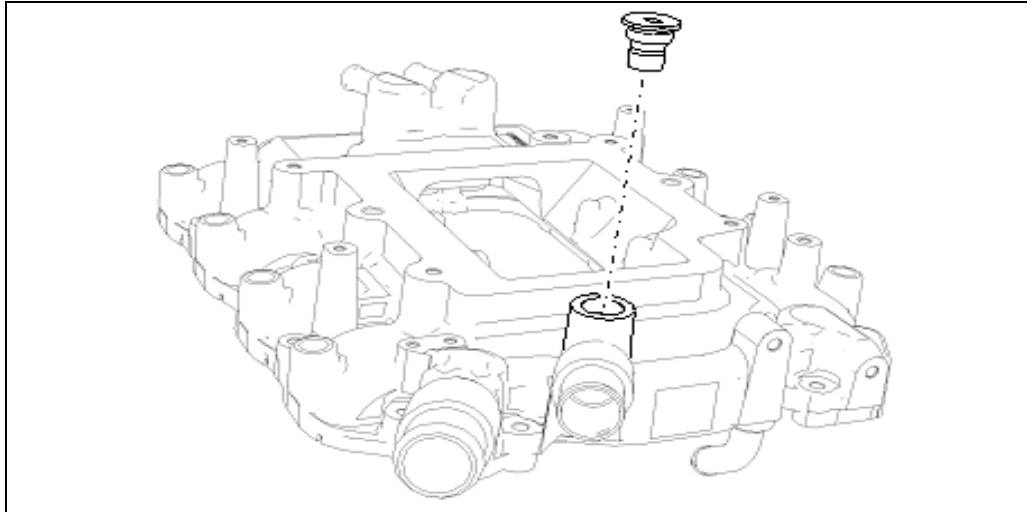

## Fuel Rail Assembly

1. Install the take off injector clips onto the new Fuel Injectors (R14010001) from Hardware Kit C. Apply assembly lube to the injector O-rings and install them into the new Fuel Rail (R07110001). Verify that the injector clips are properly seated onto the fuel rail injector cups.

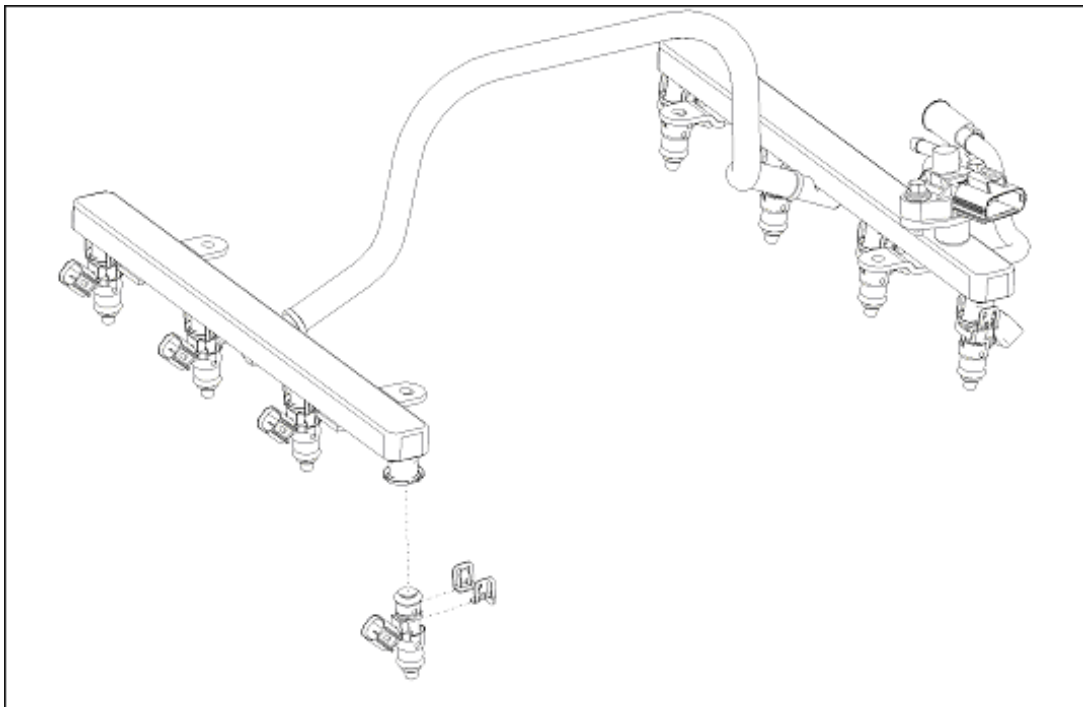

# ROUSH

THE **ART** OF PERFORMANCE ENGINEERING

PREMIUM FUEL REQUIRED

## SECTION D – INSTALLATION

The following section will guide you through the final installation of the kit into the vehicle. If you need to stop during any part of the installation, make sure you cover any open ports in the cylinder heads or intake manifold to prevent foreign material from contaminating your engine.

### Intercooler Reservoir Mounting

1. Using the Intercooler Degas Bottle (R07070007) with Degas Bottle Cap (XL3Z-8100-AA) as a template, place the bottle on the flat part of the electric fan shroud between the power steering reservoir and the engine coolant degas bottle. With the edge of the bottle at the edge of the electric fan shroud, mark the two mounting holes with a paint pen and drill two 5/16" holes through the fan shroud.

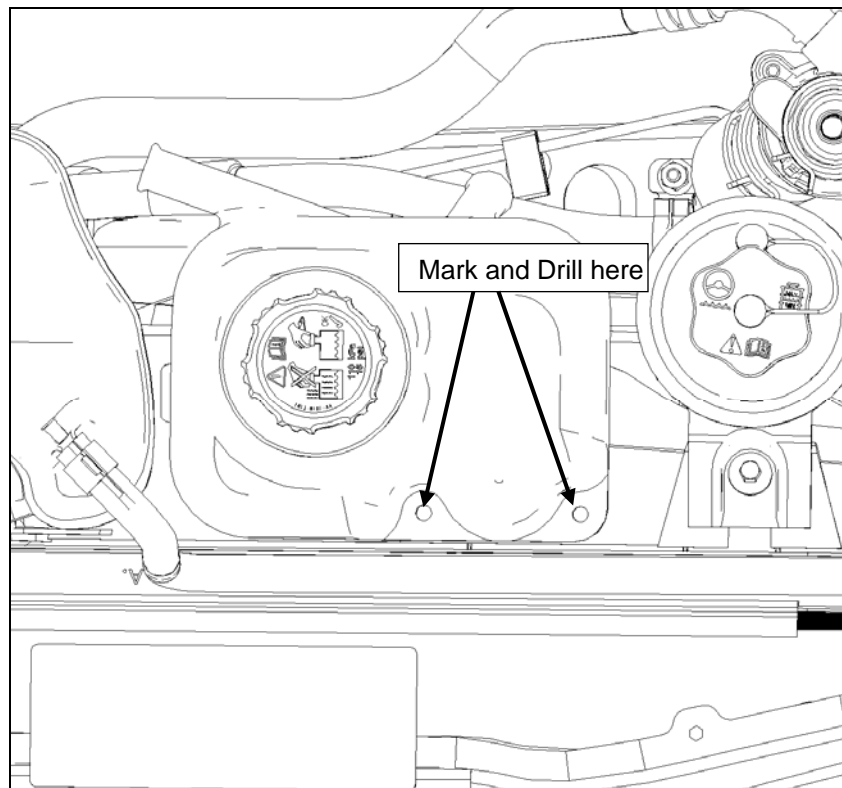

# ROUSH

THE ART OF PERFORMANCE ENGINEERING

PREMIUM FUEL REQUIRED

2. Cut out the following template and use it to mark the third mounting hole and drill to 5/16".

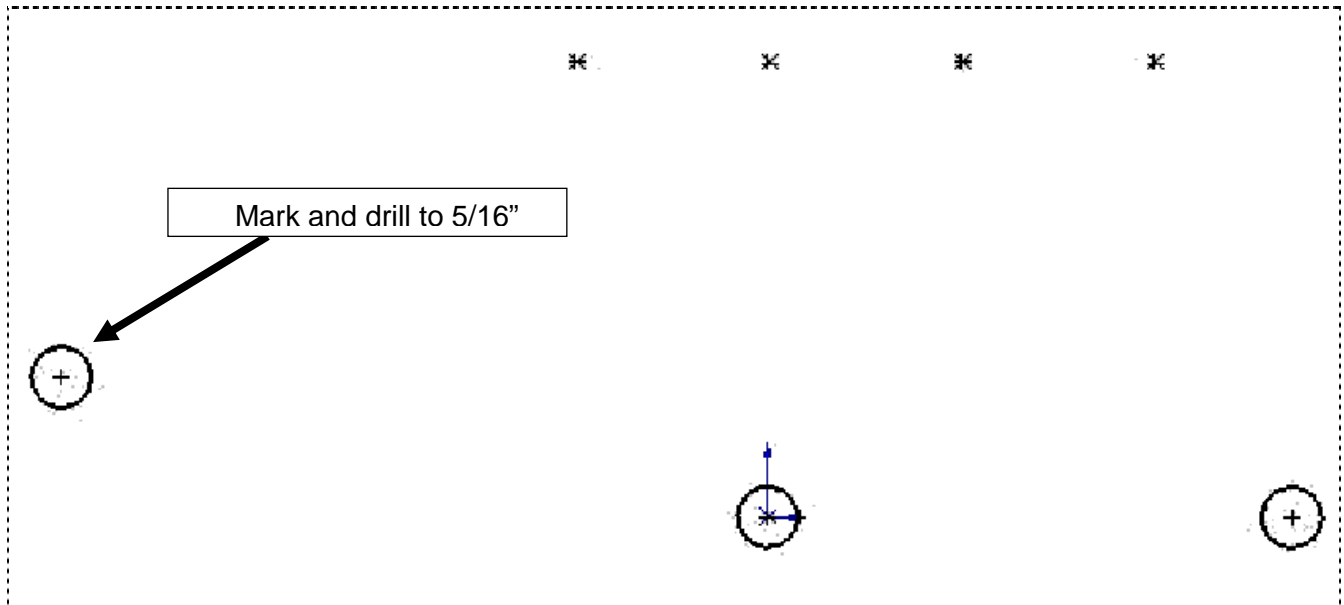

3. Clean the mating surfaces of the degas bottle and fan shroud with brake cleaner or rubbing alcohol. Peel and stick one side of the Double-Sided Tape (R07030002) provided in Hardware Kit J, to the underside of the degas bottle.

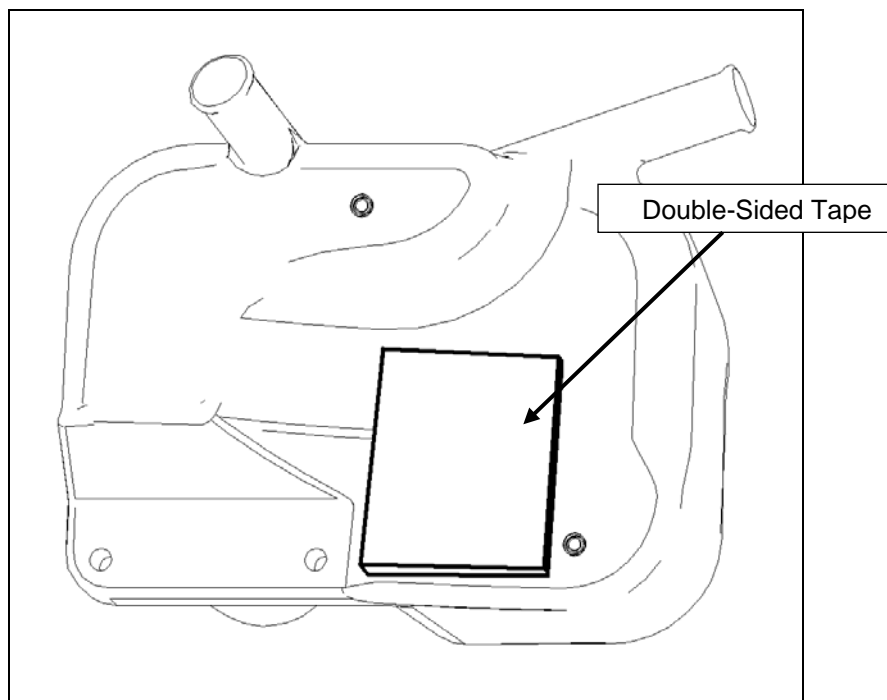

# ROUSH

THE **ART** OF PERFORMANCE ENGINEERING

PREMIUM FUEL REQUIRED

4. Remove the upper fan shroud bolts and force the shroud toward the rear of the vehicle. Install (2) J-Clips (N623332) from Hardware Kit J. Peel the second side of the double-sided tape and set the bottle on the fan shroud. Secure the intercooler degas bottle using (2) M6 x 1.0 x 33 mm bolts (N808429), and (1) M6 x 1.0 x 8 mm cap screw (R18020010) with washer (R18030002) from Hardware Kit J and torque to 8 – 12 Nm. Reinstall the upper fan shroud bolts and torque to 8 – 12 Nm.

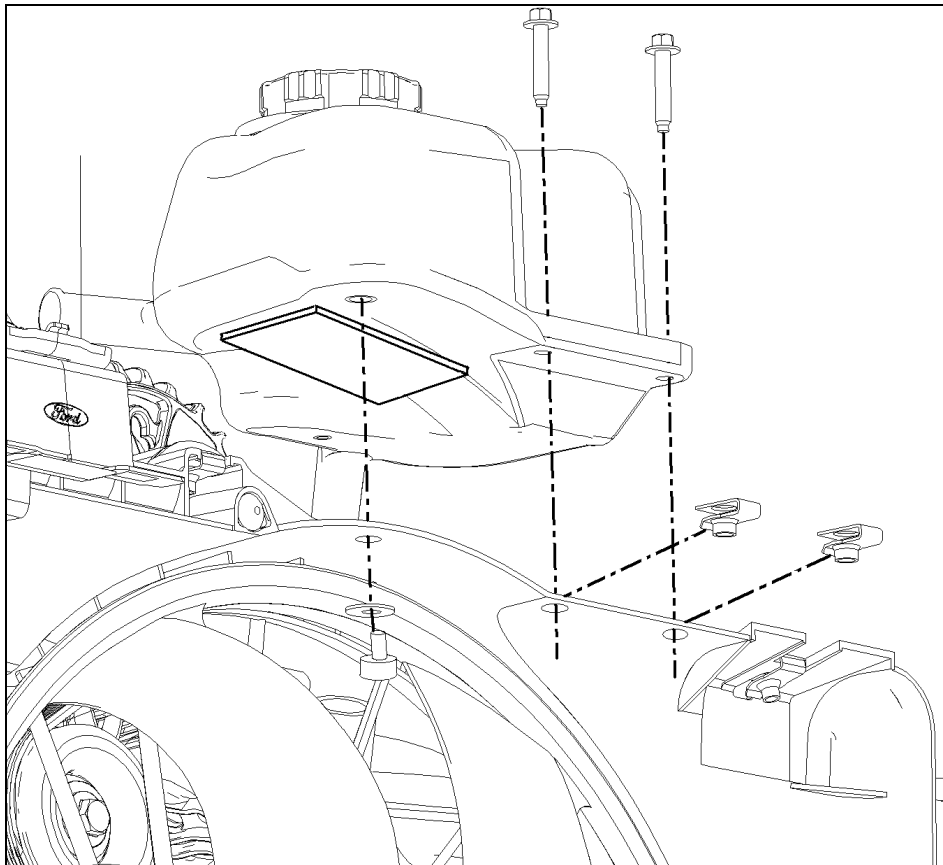

# ROUSH

THE ART OF PERFORMANCE ENGINEERING

PREMIUM FUEL REQUIRED

## Intercooler Radiator Assembly Mounting

1. Remove the six push pin retainers highlighted below by pulling the center pin and remove the radiator trim cover.

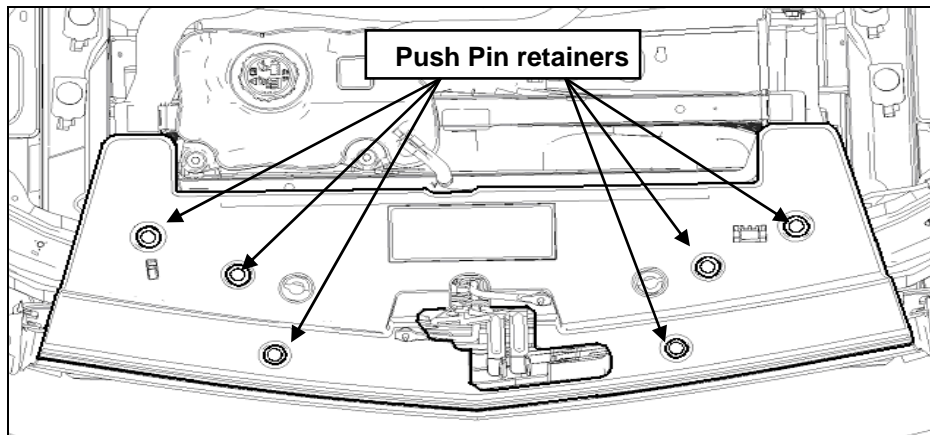

2. Raise the vehicle and remove both front tires. Remove the three forward Phillips-head screws from each front wheel liner. Using a Phillips-head screwdriver, turn the five inner fender push pins  $\frac{1}{4}$  turn to release the centers. Remove the pushpins and then remove the forward inner fenders.

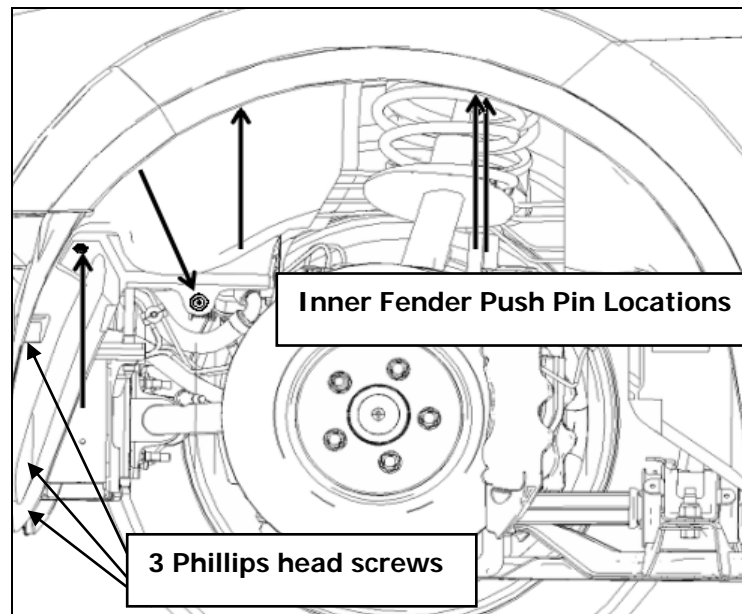

# ROUSH

THE **ART** OF PERFORMANCE ENGINEERING

PREMIUM FUEL REQUIRED

3. Remove the three lower close-out to radiator support screws (7mm). Remove the two upper bumper cover screws near the headlights (10mm). Remove the four front fender to bumper cover nuts inside the forward wheel well (10mm).

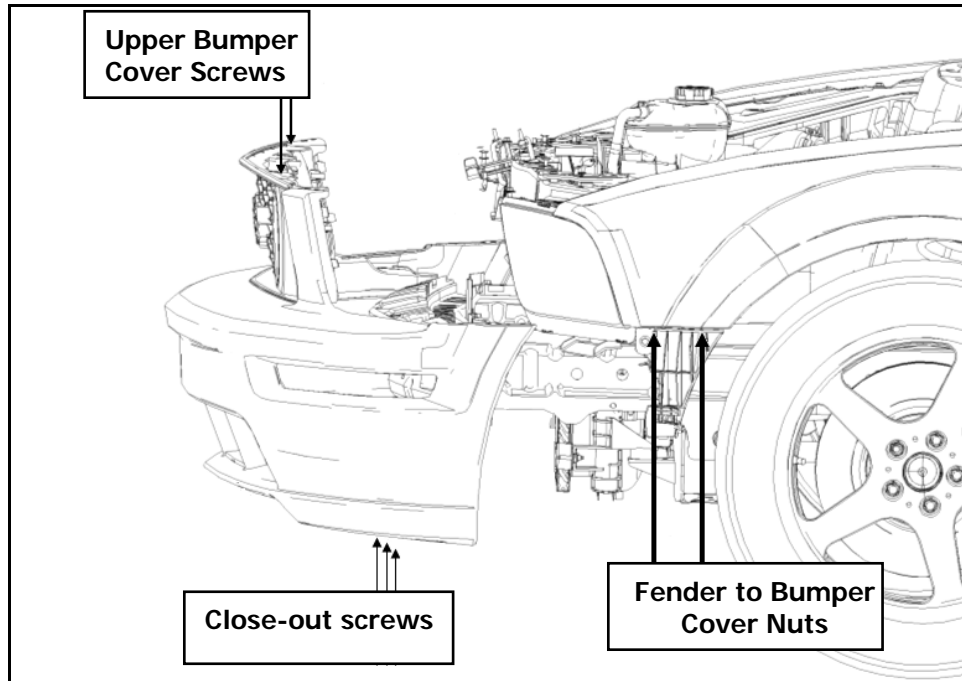

4. Reach inside the front wheel wells and unplug the front turn signals (there are four connectors total). Lift the front bumper cover slightly and pull partially off of the vehicle. Unplug the fog lights and set the front bumper cover aside.
5. Remove the four push pins that retain the impact absorber to the front bumper beam and set the absorber aside.

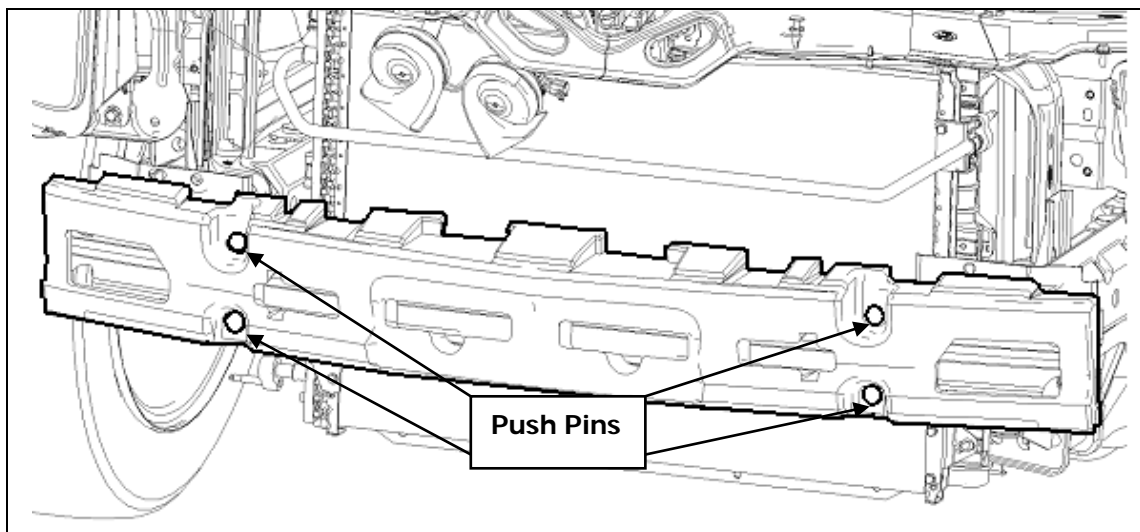

# ROUSH

THE ART OF PERFORMANCE ENGINEERING

PREMIUM FUEL REQUIRED

6. Remove the four inner front bumper beam bolts. Save one bolt for reuse later.

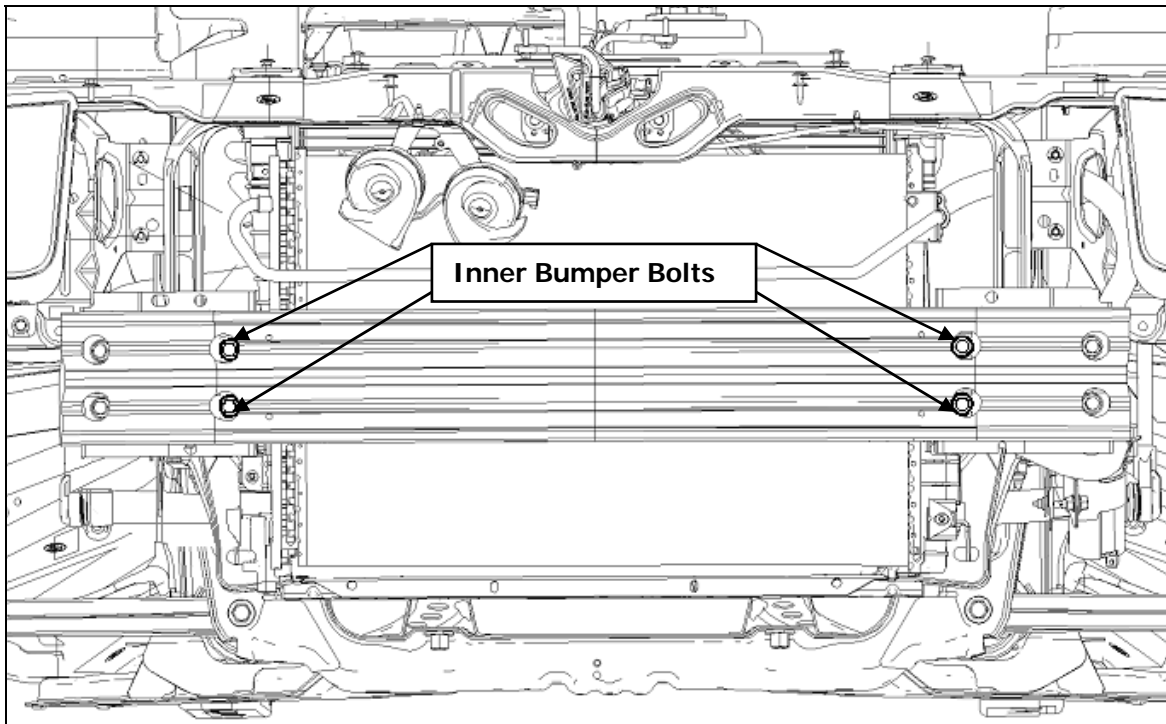

7. Install (4) Long Bumper Bolts (R18020007) from Hardware kit J in place of the four which were just removed and torque to 20 – 30 Nm. Install the Intercooler Radiator Assembly (R07060084) behind the bumper onto the new long bumper bolts. Install (4) LTR Mounting Nuts (W520413) from Hardware Kit J on the exposed end of the long bumper bolts and torque to 20 – 30 Nm.

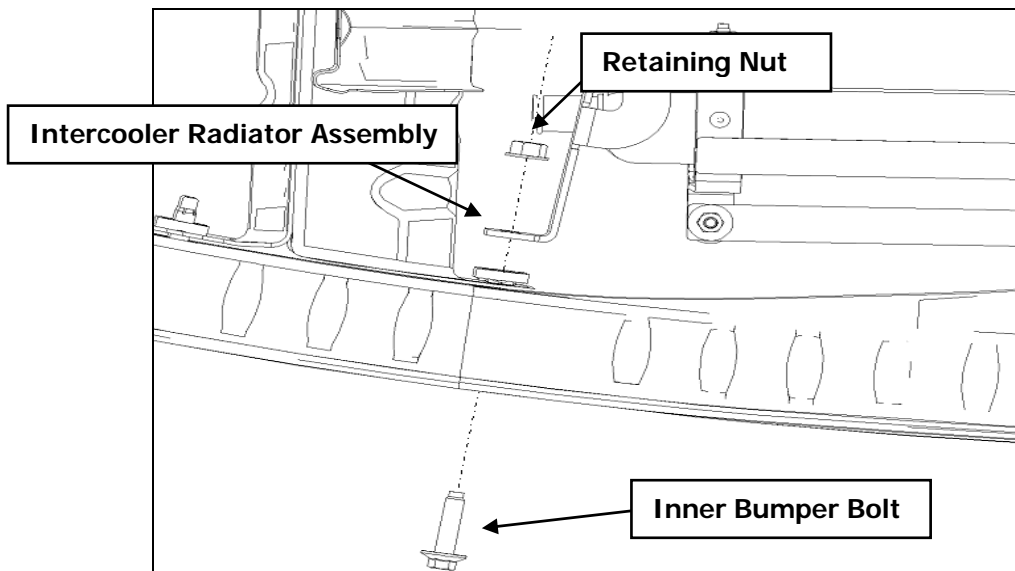



# ROUSH

THE **ART** OF PERFORMANCE ENGINEERING

PREMIUM FUEL REQUIRED

8. Reinstall the impact absorber onto the front bumper beam using the take out pushpins.
9. Install the 12 ½" LTR Inlet Hose on the driver side of LTR with (1) ¾" constant tension clamp (81) and leave hanging. Install the 33 ¾" LTR Outlet Hose on the passenger side of the LTR with (1) ¾" constant tension clamp (81) and route up through the fender and into the engine compartment as illustrated below.

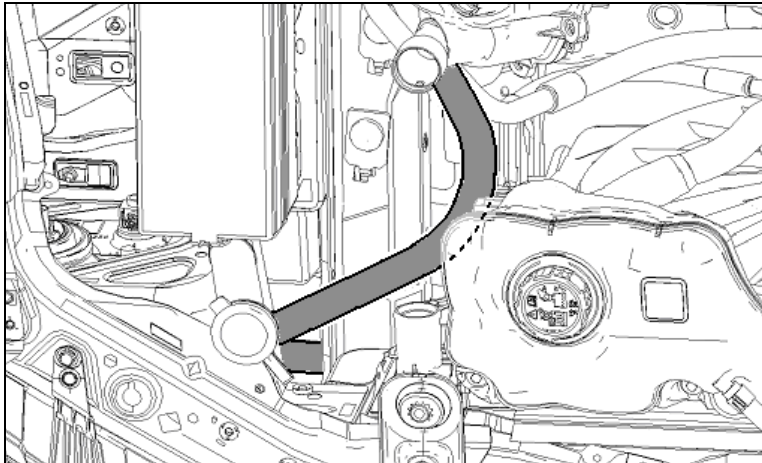

## Electric Water Pump Bracket Mounting

1. Cut out the following template. Line up the template with the tie down bracket inside the driver side wheel well. Center punch the "X"s marked on the template into the frame rail of the vehicle. Drill two ¼" holes through the frame rail and de-burr the holes.

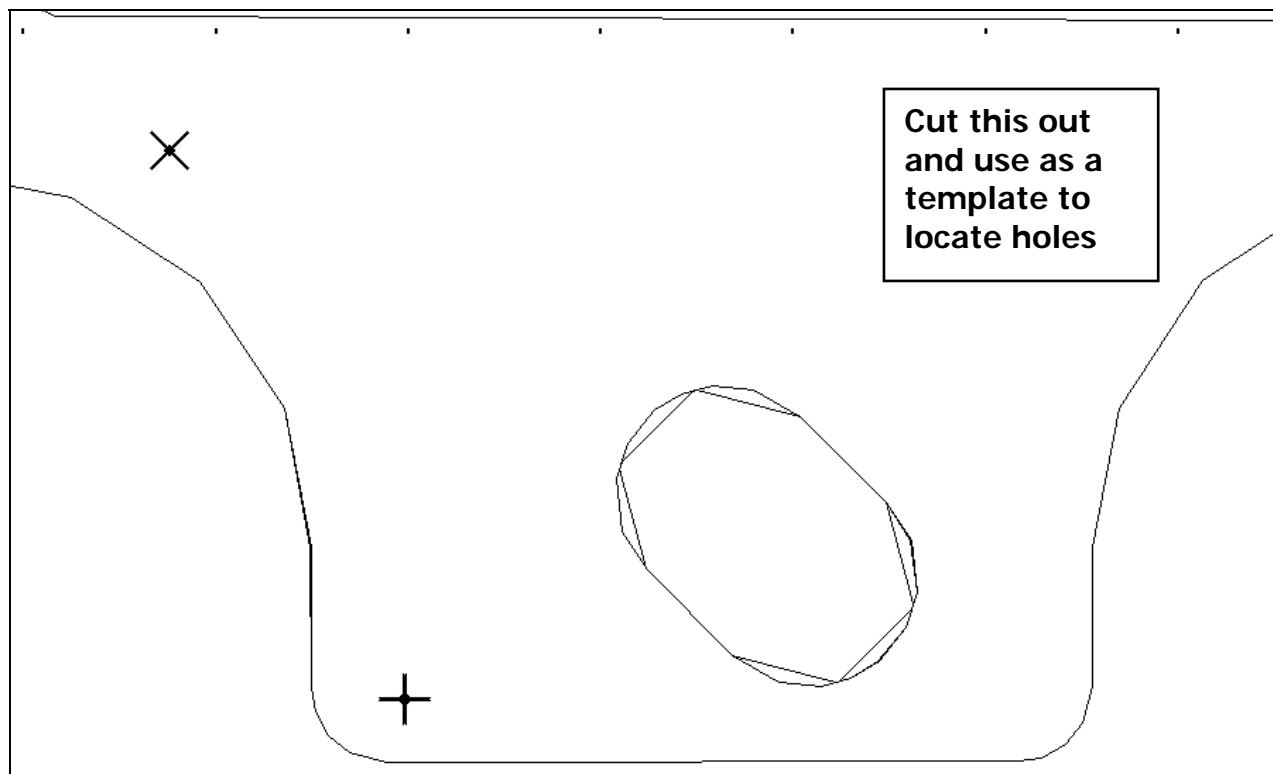



This page left intentionally blank.

# ROUSH

THE ART OF PERFORMANCE ENGINEERING

PREMIUM FUEL REQUIRED

2. Install (2) J-Clips (N623332) from Hardware Kit J and mount the Intercooler Pump Mounting Bracket (R07070015) using (2) M6 x 1.0 x 18 mm bolts (N605891) onto the body. Torque bolts to 8 – 12 Nm. Slide the Intercooler Pump (F8YZ-8501-AA) into the bracket and secure using the bumper bolt removed earlier and a M8 nut (W520413) from Hardware Kit J. Torque the nut and bolt to 8 – 12 Nm.

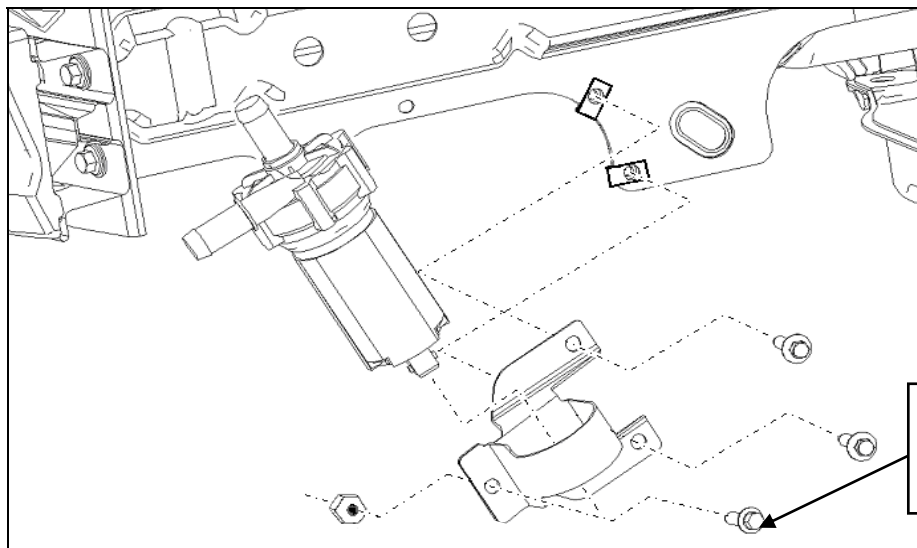

3. Connect the 12 1/2" LTR Inlet Hose (previously installed to LTR) to the outlet of the pump with (1) 3/4" constant tension clamp (81). Install the 31" Degas Bottle Outlet Hose onto the pump inlet with (1) 3/4" constant tension clamp (81). Route the Degas Bottle Outlet Hose up through the fender to the Degas Bottle as illustrated. Connect this hose to the bottom outlet of the Degas bottle using (1) 3/4" constant tension clamp (81).

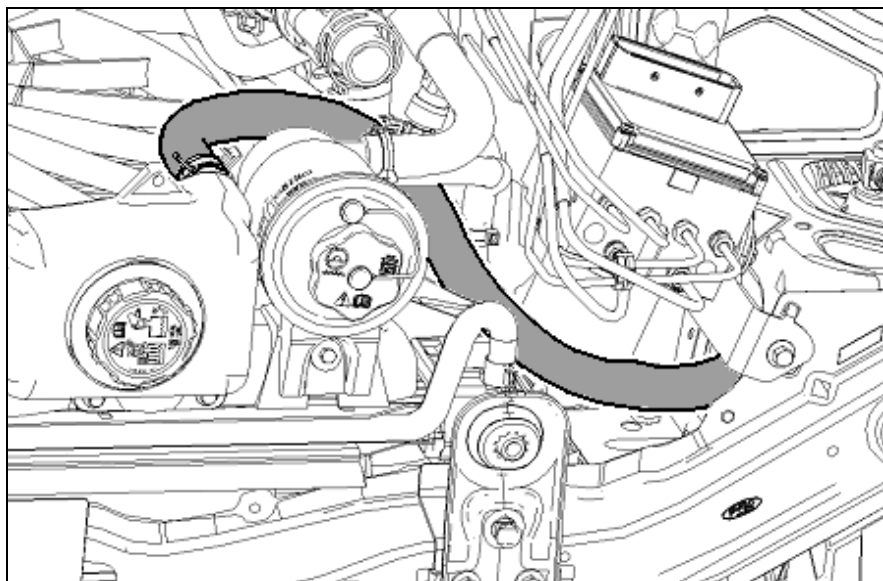
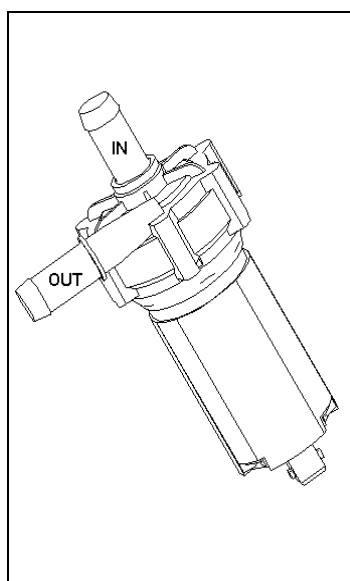

**Note:** Route all intercooler hoses very carefully. It is critical to the intercooler performance that these hoses are not kinked once installed into the vehicle.

# ROUSH

THE ART OF PERFORMANCE ENGINEERING

PREMIUM FUEL REQUIRED

## Electric Water Pump Harness

1. Locate the square 12-pin (2005 model year) or 16-pin (2006 model year) connector near the three processor connectors. Unplug the connector and remove the short section of convoluted tubing and electrical tape from the harness immediately behind the chassis side connector. Locate the red wire in pin location #10 (2005 model year) or pin location #2 (2006 model year). Cut this red wire about 1 1/2 inches back from the connector.

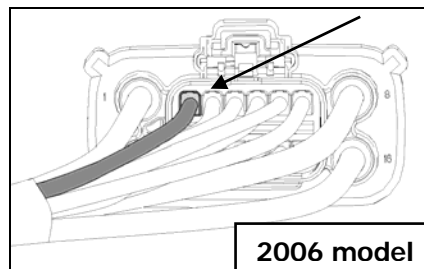
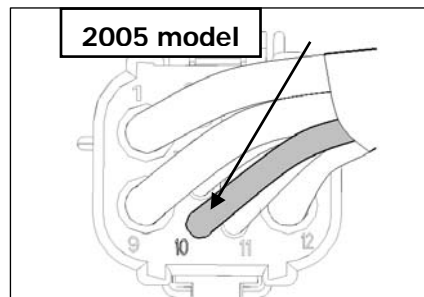
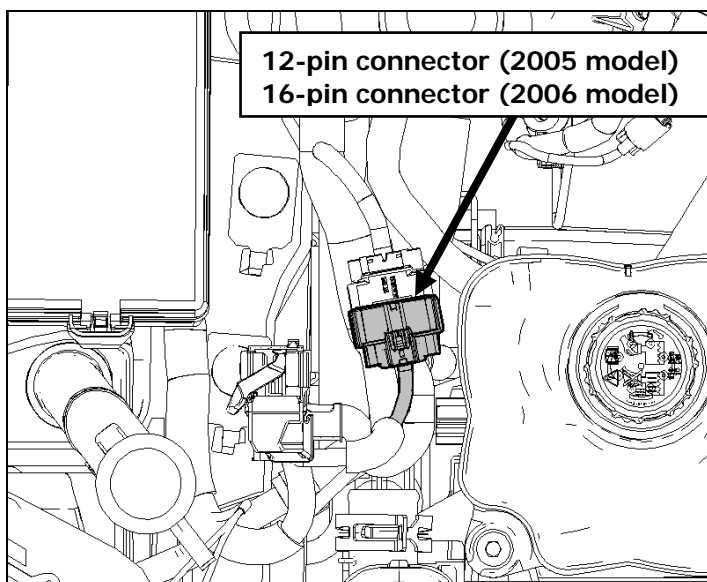

2. Seal the connector end of the red wire using one piece of heat shrink provided with the Intercooler Pump Wiring Harness Kit (R07080006).

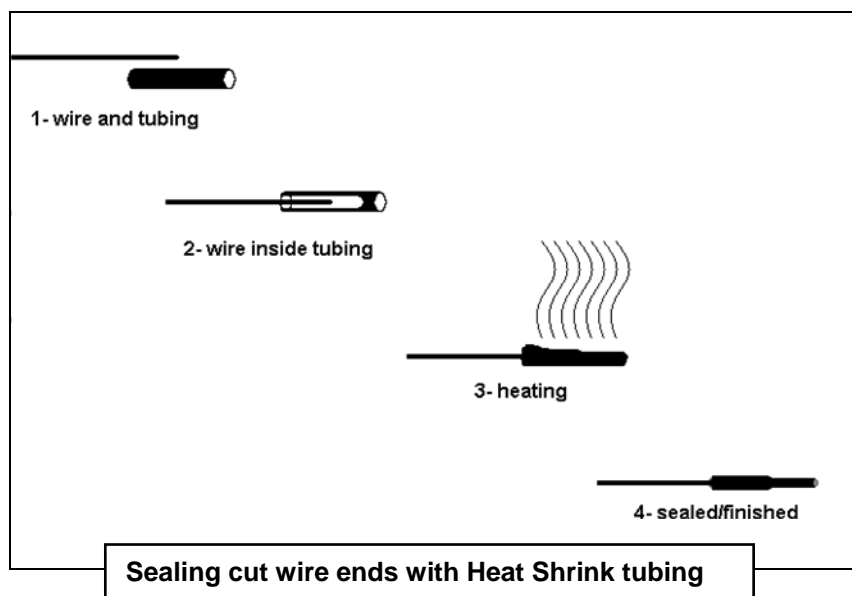

# ROUSH

THE ART OF PERFORMANCE ENGINEERING

PREMIUM FUEL REQUIRED

- Strip approximately 3/8" of insulation off the harness side of the red wire. Place a piece of supplied heat shrink tubing over the non-terminated end of the Intercooler Pump Wiring Harness. Strip approximately 3/8" of insulation off the end of the intercooler wire and connect to the red wire using the provided splice connector from the Intercooler Pump Wiring Harness Kit and crimp using a W-type crimping tool. Using a clean, hot soldering iron, heat the wires (not the solder) in the splice connector until they are hot enough to melt the solder touched to them. Slide the heat shrink tubing over the solder joint and heat to shrink with a heat gun. Reinstall the convoluted tubing and tape removed from the factory harness.

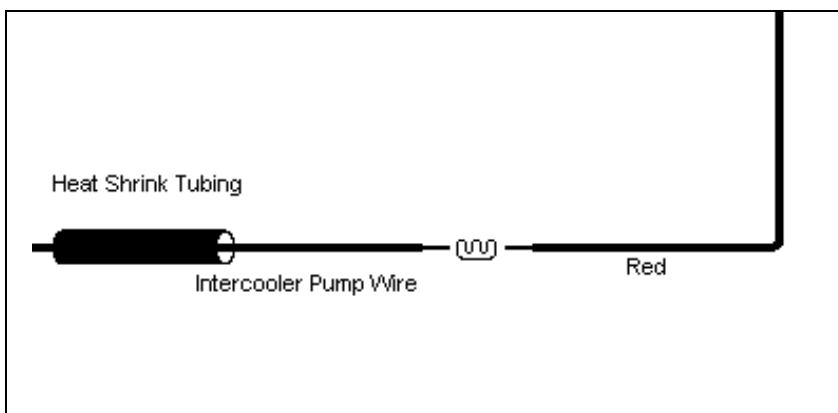

- Plug the connector back together. Route the remainder of the Intercooler Pump Wiring Harness over the radiator (following the existing harness) behind the headlamp on the driver side and into the inner fender area where the water pump bracket is mounted. Remove the top water pump bracket mounting bolt and install the wiring harness ground eyelet and re-torque the fastener. Connect the wiring harness to the electric water pump.

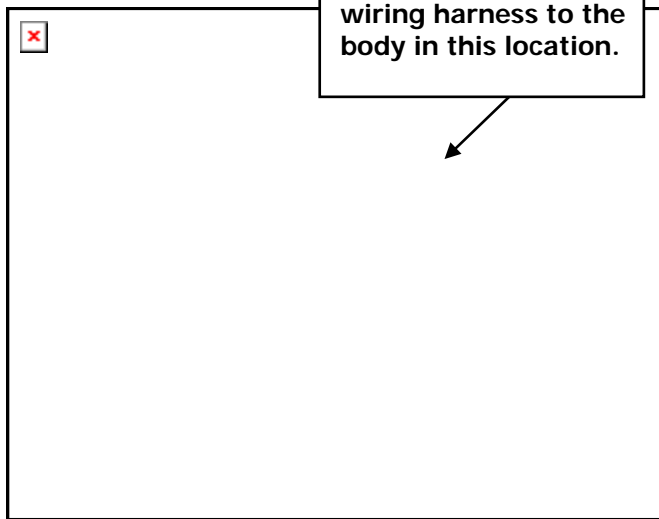
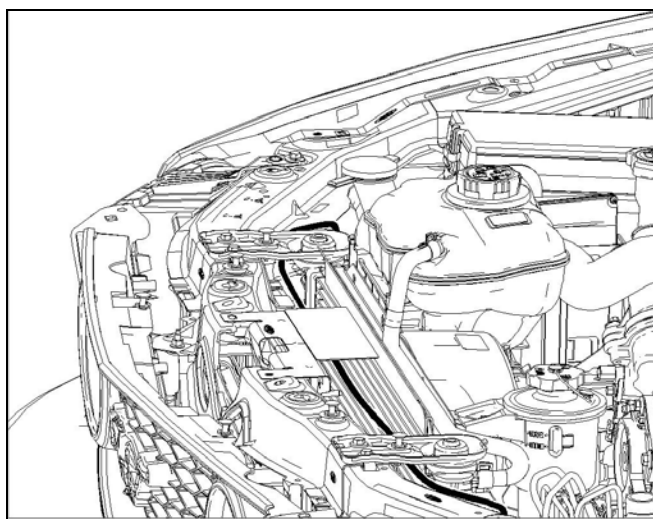

# ROUSH

THE **ART** OF PERFORMANCE ENGINEERING

PREMIUM FUEL REQUIRED

## Spark Plug Installation

1. Remove the ignition coils using a 7mm socket. Remove the original spark plugs using a 9/16" socket (spark plug type preferred). Install the new Spark Plugs (R07030001)\*. Torque to 30 – 38 Nm.

**\*Note:** Spark plugs will be shipped with your re-flashed PCM as required.

2. Reinstall the coils. Torque the coil bolts to 5 – 7 Nm.

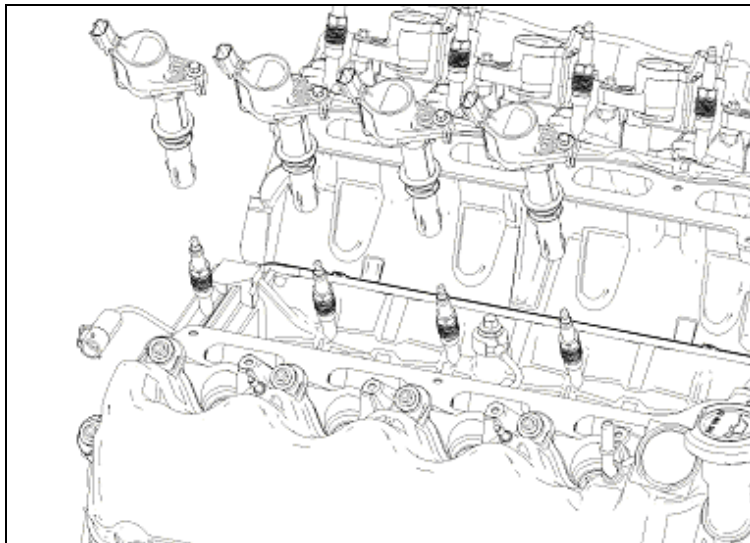

## Intake Manifold and ROUSHCharger Installation

1. Install the modified heater tube assembly using the take out stud bolt. Be sure to lube the O-rings with assembly lube before installing the heater tube to the water pump fitting in the block. Torque the stud to 8 – 12 Nm.

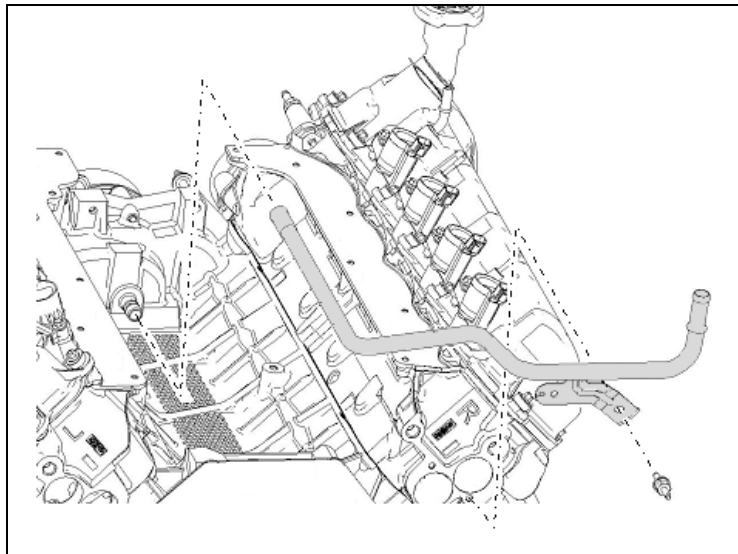

# ROUSH

THE **ART** OF PERFORMANCE ENGINEERING

PREMIUM FUEL REQUIRED

2. Remove the tape from the cylinder heads and clean the cylinder head to intake manifold mating surfaces using brake clean or rubbing alcohol.
3. Set the intake manifold assembly down onto the cylinder heads. Be careful not to damage your sealing surfaces or gaskets during this step. Insert (2) intake mounting bolts (R18020004) from Hardware Kit C into Holes A and B (shown below) and start the threads by hand. Do **NOT** tighten these fasteners. The intake must remain free to move along the cylinder head surfaces.

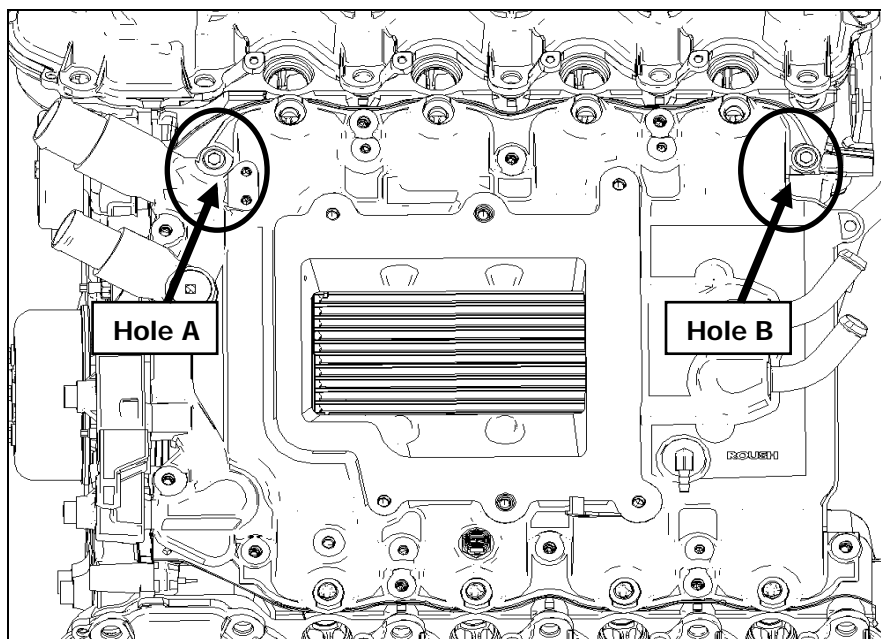

4. Install the Alternator Bracket (R07020013) onto the studs previously used to mount the alternator to the cylinder block and temporarily secure the bracket using the stock nuts.

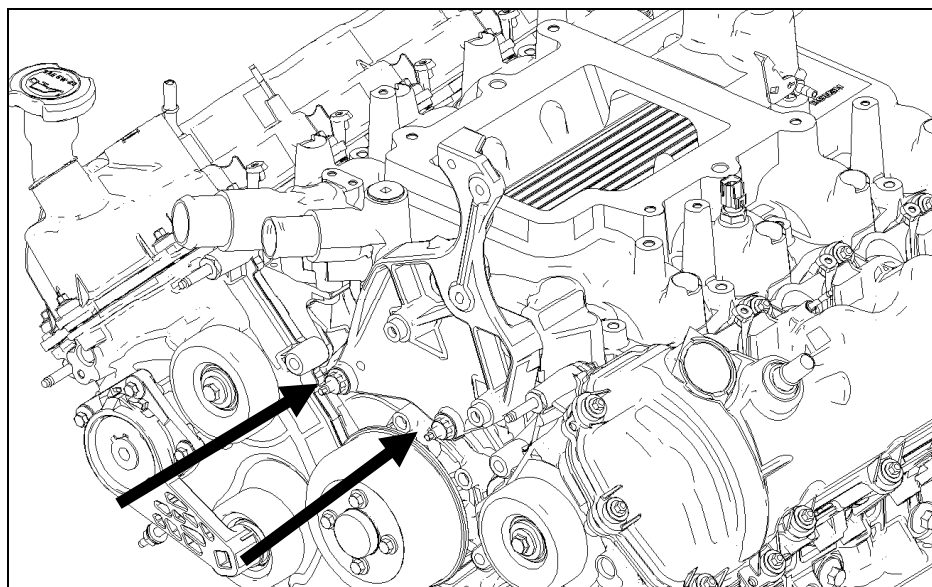

# ROUSH

THE **ART** OF PERFORMANCE ENGINEERING

PREMIUM FUEL REQUIRED

5. Use the FEAD bracket rear mounting bosses to properly align the intake manifold on the cylinder head surfaces by shifting the manifold from front to back and side to side. When you are finished, these features should be aligned in both the for-aft and side-to-side directions.

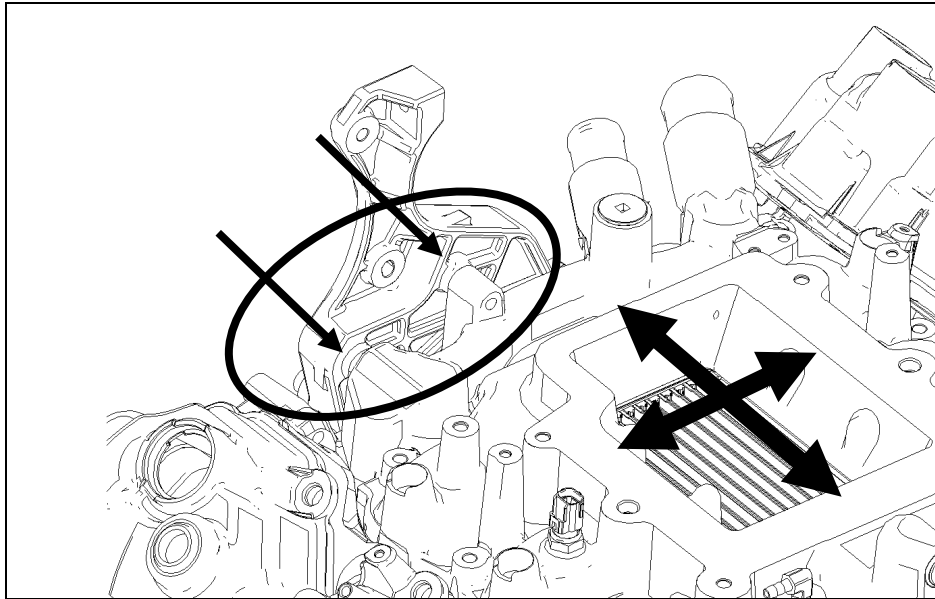

6. Once aligned, fasten the intake manifold using (11) M6 x 1.0 x 40mm bolts (R18020004) from Hardware Kit C and the stock driver side rear stud (used to retain the wiring harness). Install these fasteners in the positions shown below and torque to 8 – 12 Nm in the sequence shown. Remove the alternator bracket from the engine as it will be installed in a later step.

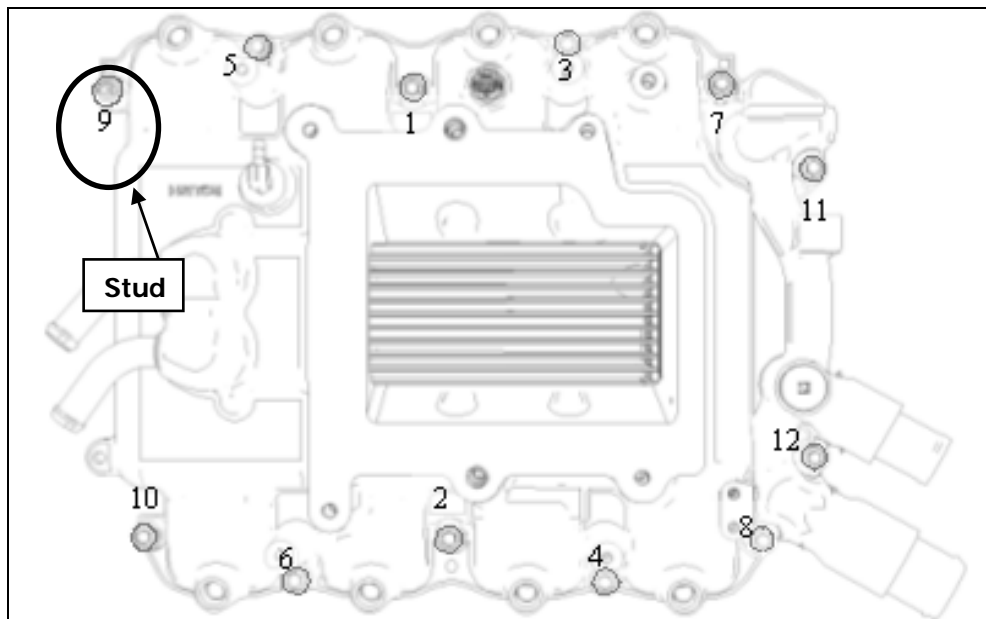



# ROUSH

THE **ART** OF PERFORMANCE ENGINEERING

PREMIUM FUEL REQUIRED

7. Install the Intercooler Tube Assembly (R07070005) from Kit I onto the passenger side cylinder head using the M16 x 40mm Tube Mounting Bolt (R18020006) for the rear and (1) M6 x 1.0 x 18 mm I/C Tube Mounting Bolt (N605891) for the front from Hardware Kit J. Torque the M16 bolt to 45 Nm and the M6 bolt to 8 – 12 Nm. Carefully manipulate the wiring harness in the area shown.

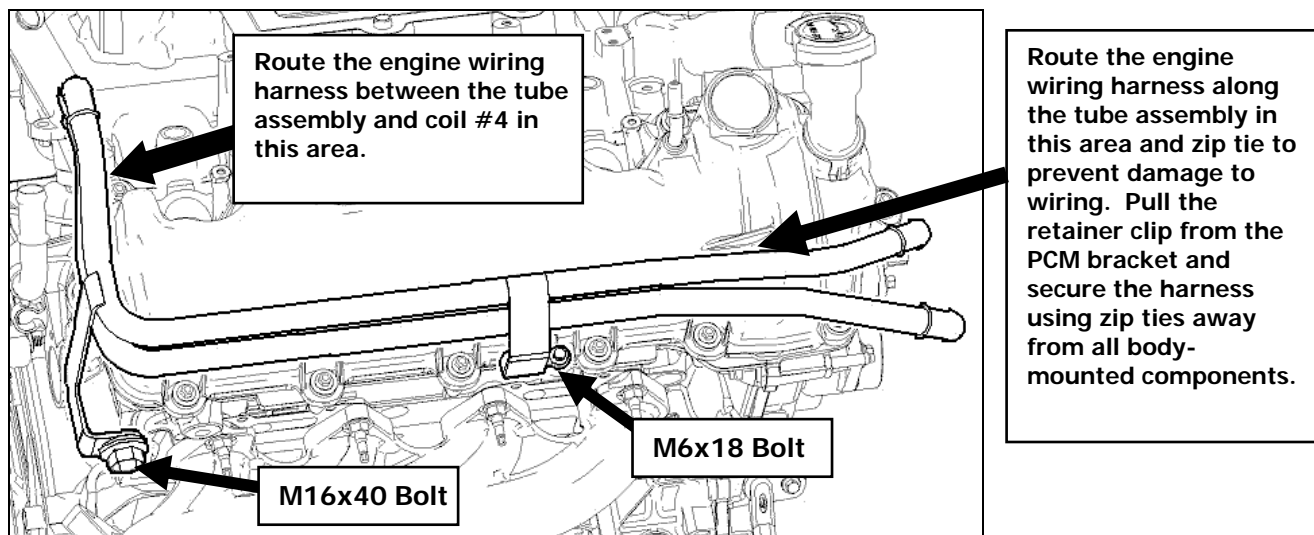

8. Install intake to ROUSHcharger gasket (G1ZE-9H486-BA) over the dowels in the upper intake. Remove the ROUSHcharger (R07050036) from the packaging and install using (6) M8 x 1.25 x 38mm bolts (W705128) provided in Hardware Kit C. Torque to 20 – 30 Nm in the sequence shown.

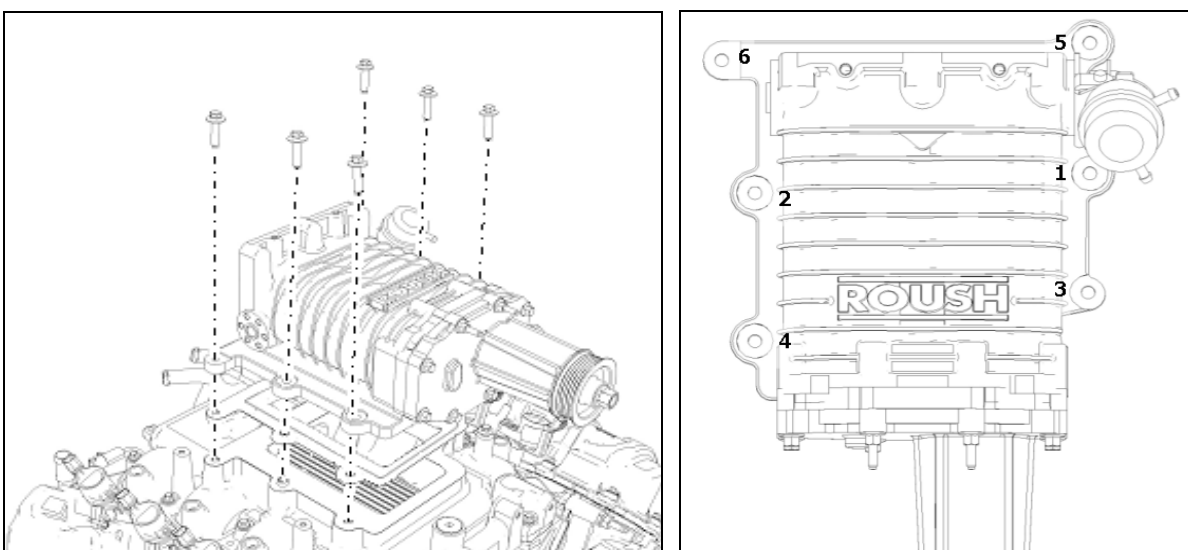

# ROUSH

THE **ART** OF PERFORMANCE ENGINEERING

PREMIUM FUEL REQUIRED

9. Lube the fuel injector o-rings with assembly lube. Install the fuel rail and injectors into the intake manifold using the take off stud bolts and torque to 8 – 12 Nm. Be sure each injector is properly seated into the intake manifold.

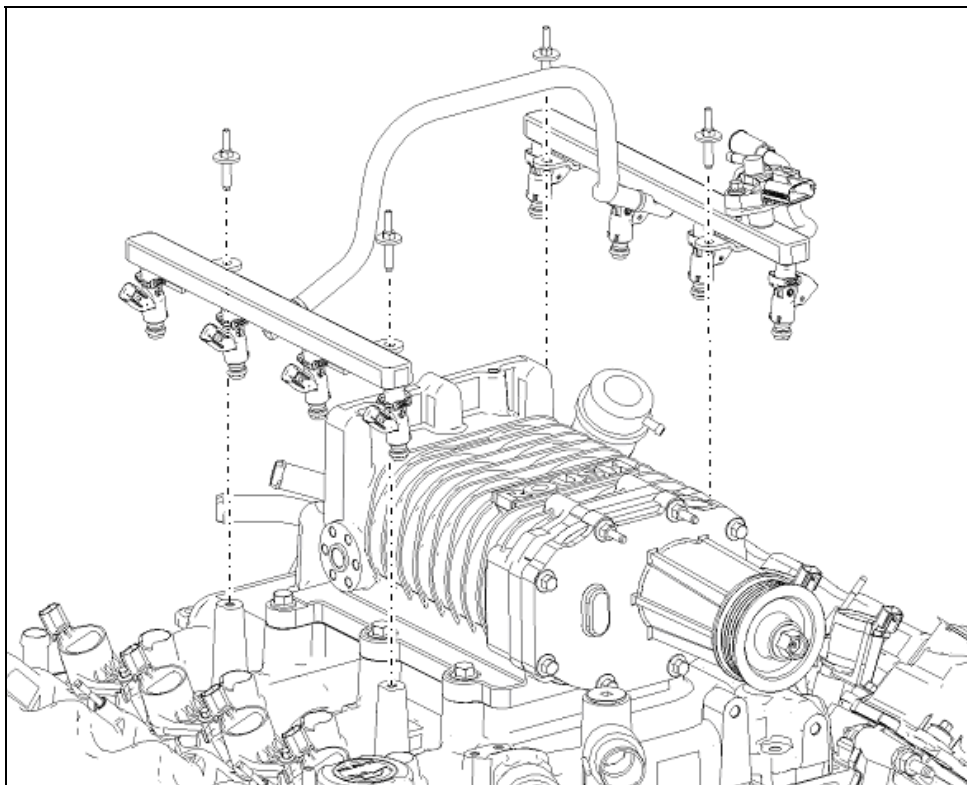

10. Connect the IPTS, ACT, and all eight fuel injector and coil connectors. Route the MAF wiring across the manifold on the driver side between the valve cover and the fuel rail.

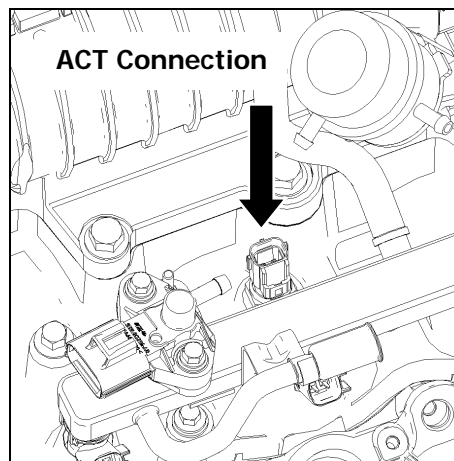
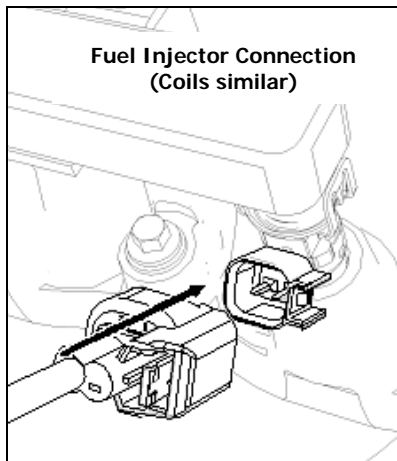
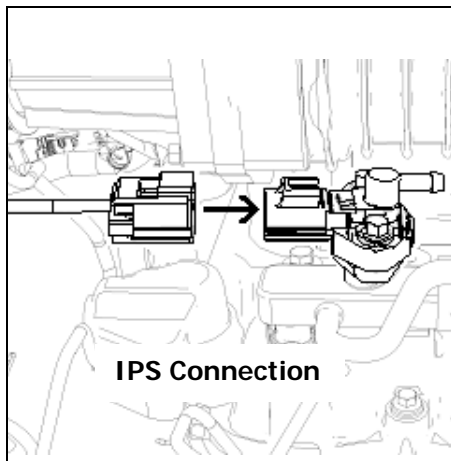

# ROUSH

THE ART OF PERFORMANCE ENGINEERING

PREMIUM FUEL REQUIRED

## FEAD Assembly

1. Install the Alternator Bracket (R07020013) onto the studs previously used to mount the alternator. Position the bracket onto alternator studs and loosely secure with the take-off M8 nuts. Use (2) M8 x 1.25 x 38mm bolts (W705128) from Hardware Kit D and to secure the alternator bracket to the intake manifold. Torque all nuts and bolts to 20 – 30 Nm.

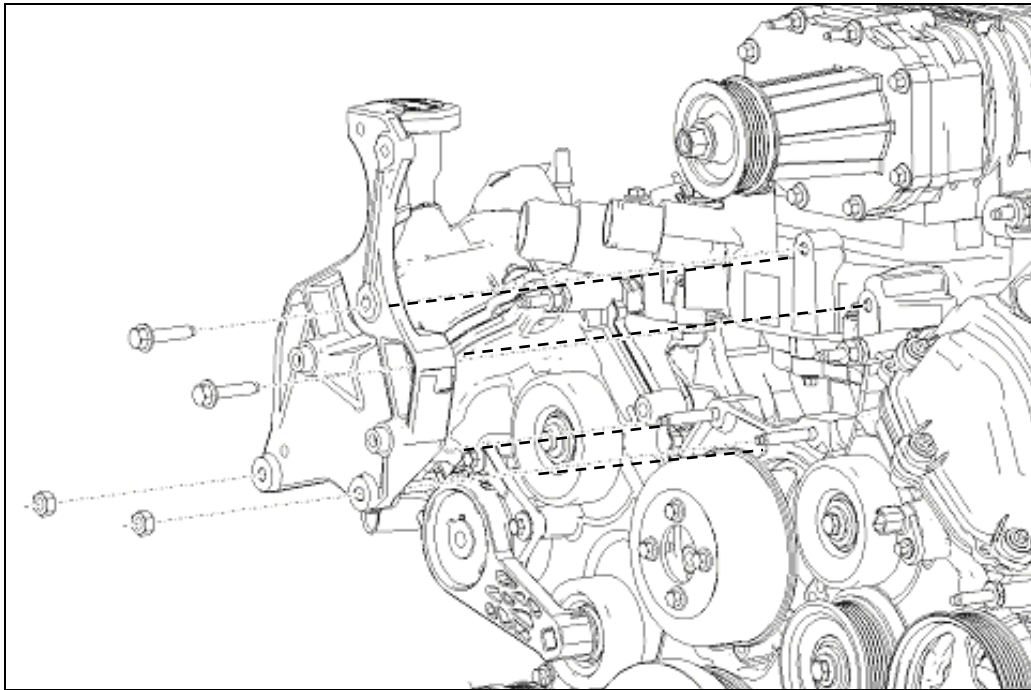

2. Install the Supercharger Studs to Alternator Bracket (R07020018) from Hardware Kit D using (2) M6 nuts (W520412) and (1) M8 x 1.25 x 25mm bolt (W500224) also from Hardware Kit D. Torque the nuts to 8 – 12 Nm and the bolt to 20 – 30 Nm.

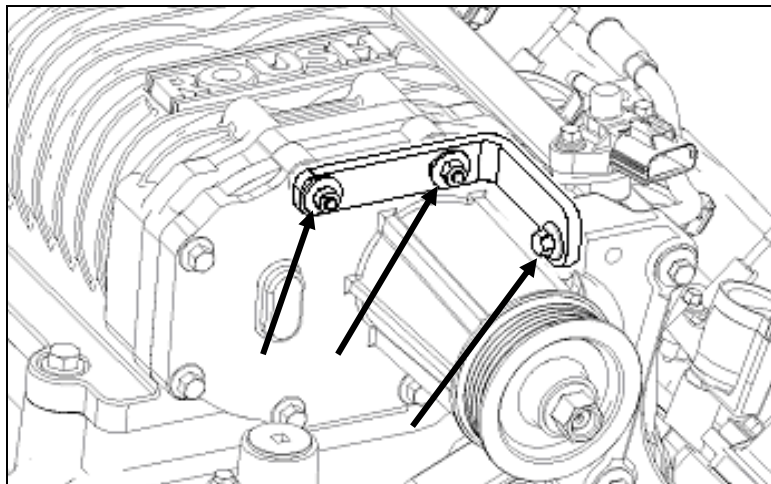

# ROUSH

THE ART OF PERFORMANCE ENGINEERING

PREMIUM FUEL REQUIRED

3. Insert (2) M8 x 1.25 x 55mm Bolts (N808130) and (2) M8 Nuts (W520413) from Hardware Kit D through the alternator bracket. Be sure to leave enough room to insert the alternator. Slide the alternator onto the bolts and torque to 20 – 30 Nm.

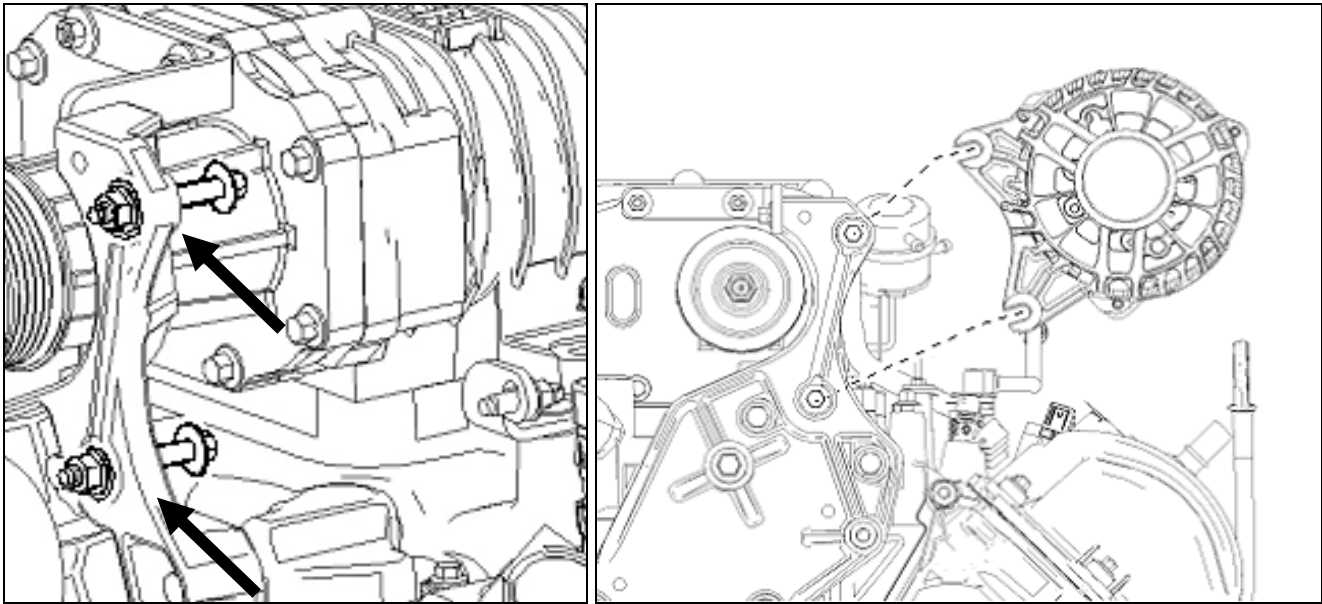

4. Install the Rear Alternator Support Bracket (R07020017) using (1) M8 x 1.25 x 20mm bolt (R18020005) into the alternator and (1) M8 x 1.25 x 25mm bolt (W500224) into the intake (all parts are from Hardware Kit D). Torque to 20 – 30 Nm.

**WARNING: Do not put any bolt longer than 20mm into the back of the alternator**

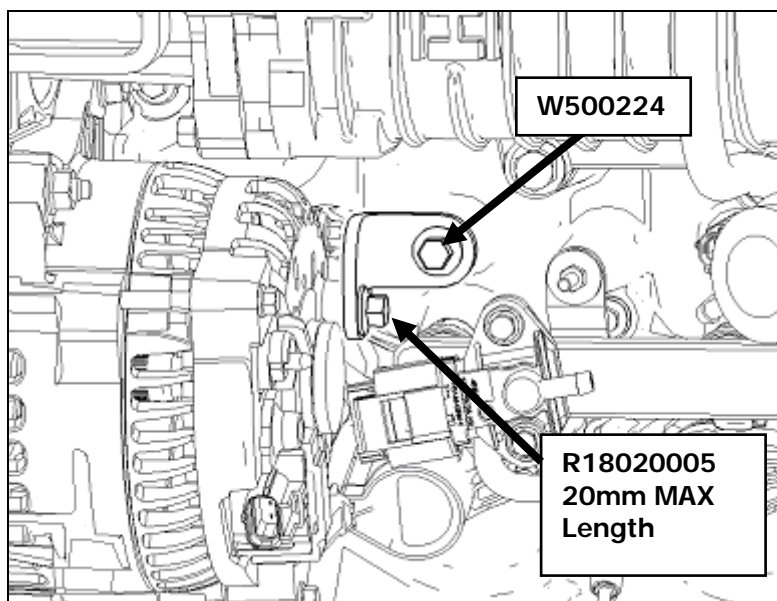

# ROUSH

THE ART OF PERFORMANCE ENGINEERING

PREMIUM FUEL REQUIRED

- Using the alternator battery cable (R07080015) from Hardware Kit F, locate the dash panel retainer (Christmas tree) and clip to the factory dash panel tab. Route the harness under the fuel rail crossover hose and install the stud retainers onto the fuel rail studs. Connect the four-pin connector from the battery cable to the four-pin connector clipped to the engine wiring harness (located near injector number one). Route both the battery and regulator ends of the harness across the front of the intake manifold (beneath the supercharger nose piece). Continue routing both ends between the rear alternator support bracket boss and the supercharger, around the front of the fuel rail mounting boss, under the fuel rail between injectors #5 and #6, and underneath the engine harness. Connect the alternator battery cable to the alternator stud and torque to 8 – 12 Nm. Plug in the alternator regulator connector.

**Note:** If alternator cable is rubbing on any sharp edges, carefully bend the cable to provide adequate clearance.

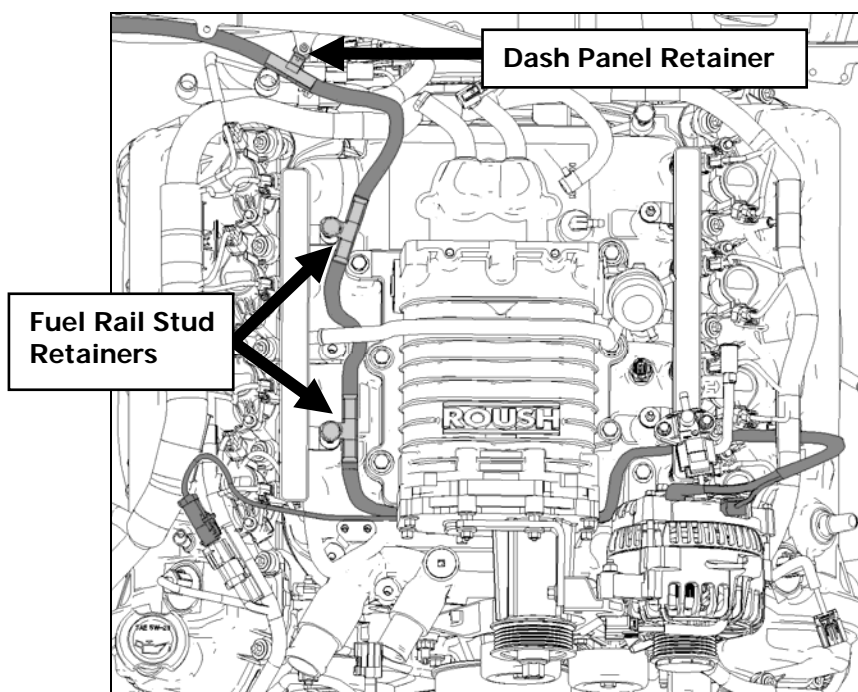

- Install FEAD Pulleys (R07020049) to the alternator bracket using (2) M8 x 1.25 x 28mm Idler bolts (R18020060). All parts can be found in Hardware Kit D. Torque bolts to 20 – 30 Nm.

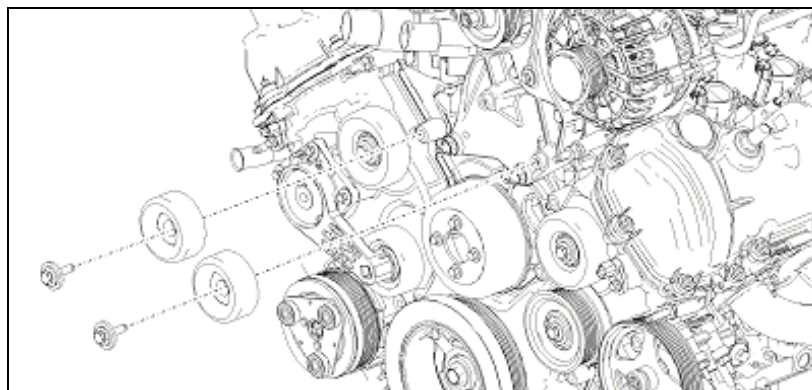

# ROUSH

THE **ART** OF PERFORMANCE ENGINEERING

PREMIUM FUEL REQUIRED

7. Install the FEAD belt (R07020015) as shown. Using a ½ inch drive breaker bar or ratchet, rotate the belt tensioner clockwise and install the supplied belt.

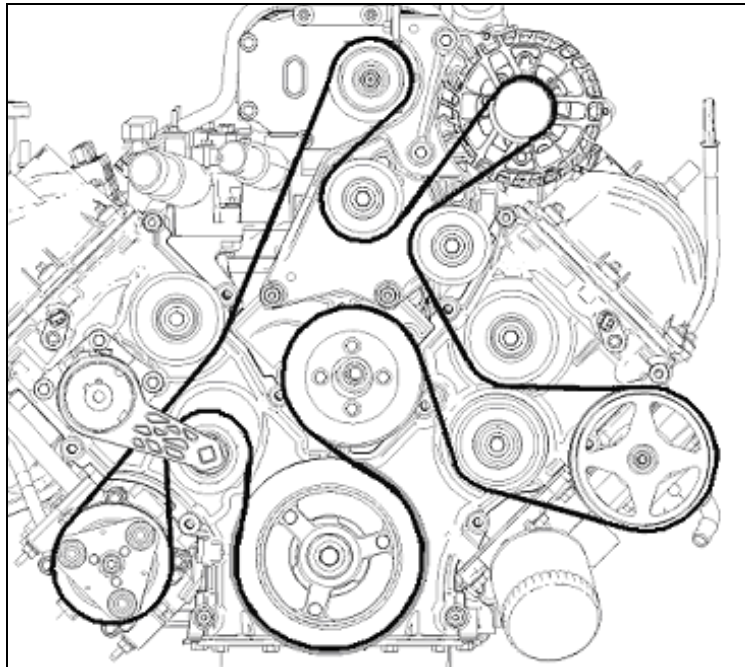

8. Reinstall the modified coolant hose hanger bracket and radio noise capacitor using the take-off M8 nut. Before tightening, ensure there is sufficient clearance to all FEAD components. Torque the nut to 20 – 30 Nm.

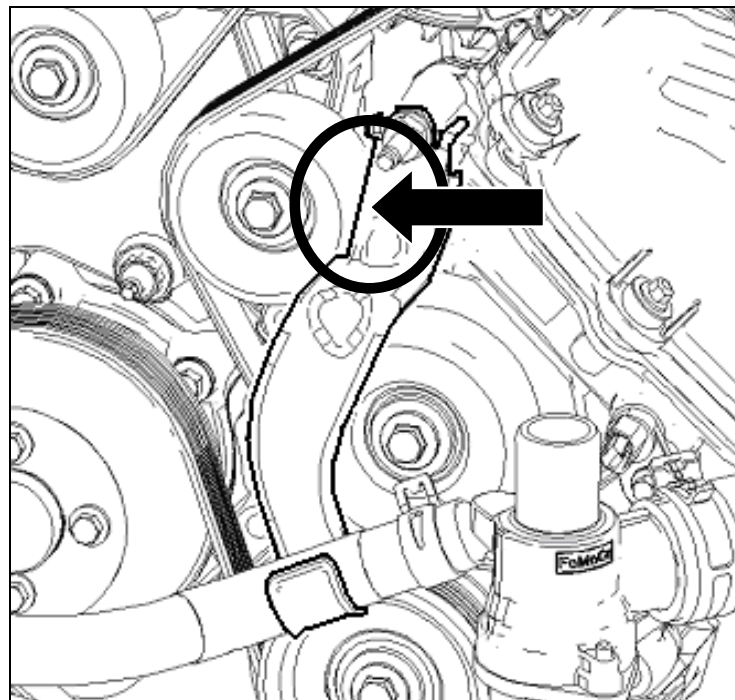

# ROUSH

THE **ART** OF PERFORMANCE ENGINEERING

PREMIUM FUEL REQUIRED

## Air Intake System

1. Install the S/C to Spacer Gasket (G1ZE-9L437-BA) from Hardware Kit C and Throttle Body Spacer (R07060041) using (6) Spacer to S/C Bolts (N808920) from Hardware Kit C. Torque bolts to 20 – 30 Nm in sequence.

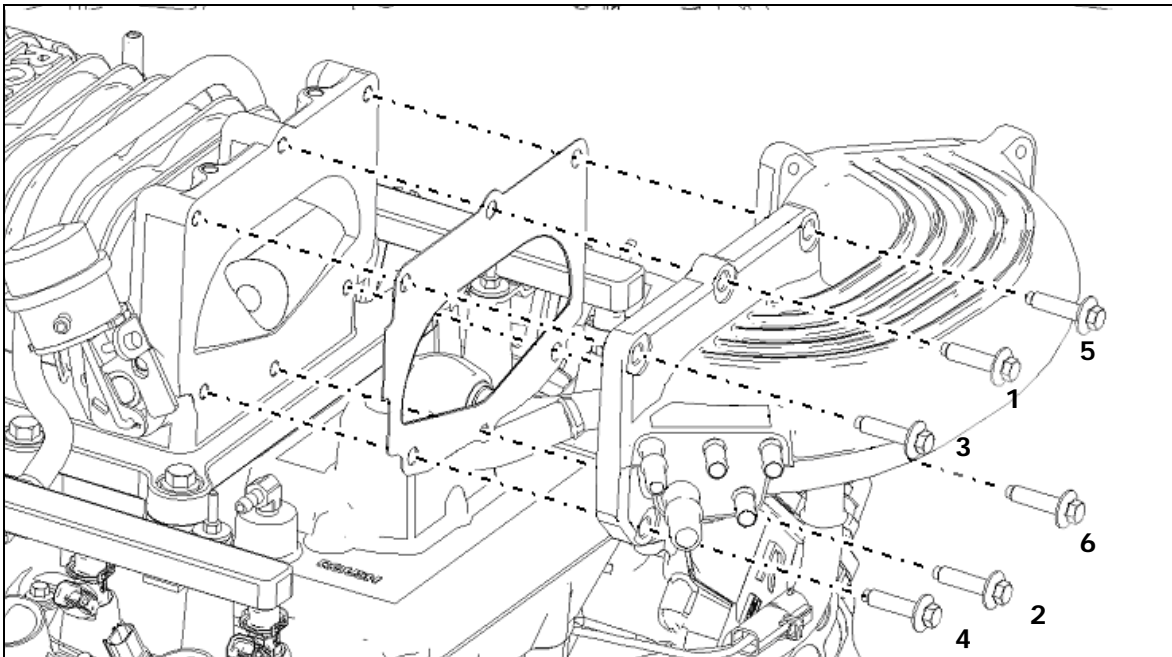

2. Install the throttle body to the throttle spacer (the gasket was installed earlier when removing it from the stock intake manifold) using (4) M6 x 1.0 x 33mm Throttle Body Bolts (N808429). Torque bolts to 8 – 12 Nm.

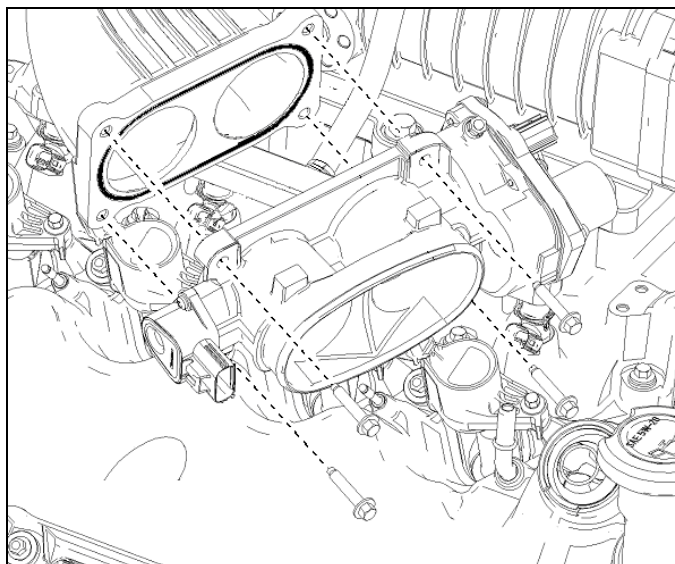

**Note:** Mount the Throttle Body so that Electronic Throttle Control Motor is on the driver side.

# ROUSH

THE **ART** OF PERFORMANCE ENGINEERING

PREMIUM FUEL REQUIRED

3. Connect the newly relocated throttle body wiring.

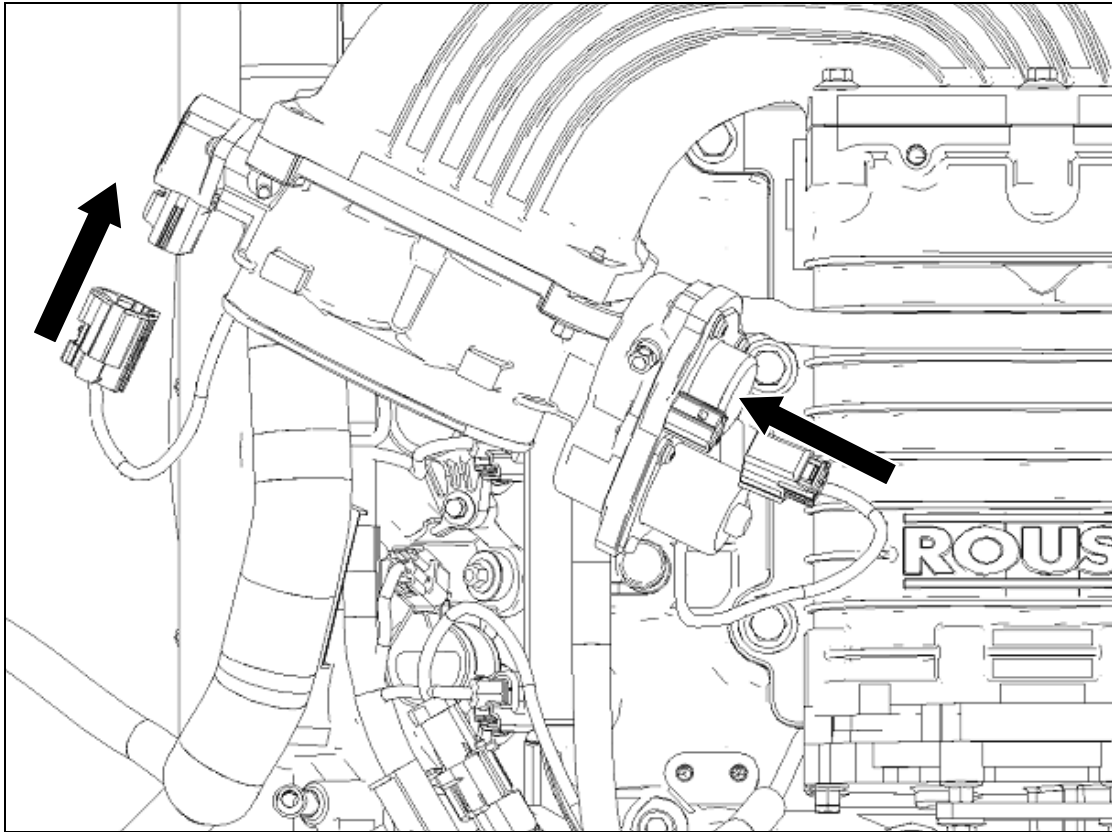



# ROUSH

THE **ART** OF PERFORMANCE ENGINEERING

PREMIUM FUEL REQUIRED

## Coolant Hoses

1. Reconnect the stock heater hoses at the back of the passenger side cylinder head using the original clamps. Install the 8" Intercooler Inlet hose and the 12 ½" Intercooler Outlet hoses using (4) ¾" constant tension clamps (81) from the intercooler hose kit.

**Note:** Ensure that the alternator charge harness installed in step #5 on page #57 is routed over both intercooler hoses once installed.

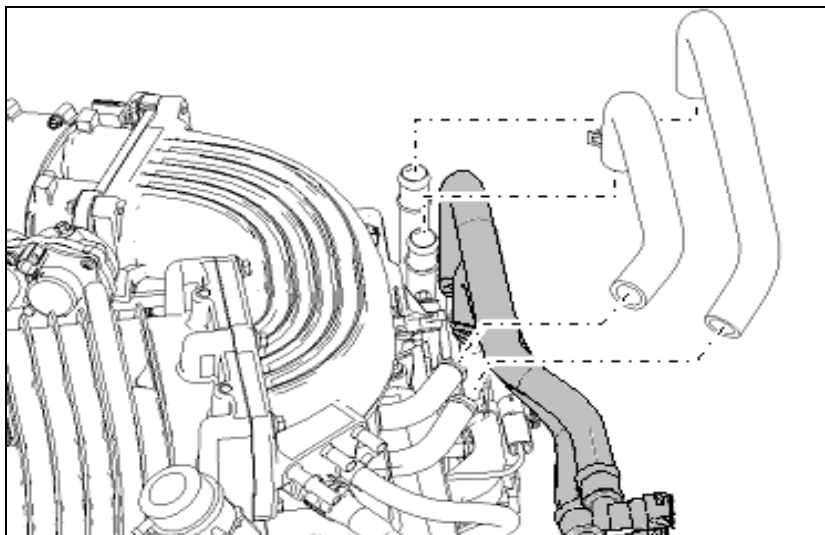

2. Connect the LTR Outlet hose routed from behind the passenger side headlamp to the lower Intercooler tube using (1) ¾" constant tension clamp (81). Install the 17 ½" Degas Inlet hose from the upper intercooler tube to the upper degas bottle fitting using (2) ¾" constant tension clamps (81) from the intercooler hose kit. Install the new Bypass Circuit Radiator Hose (R07070004) using (2) 1 ½" worm drive clamps from the intercooler hose kit.

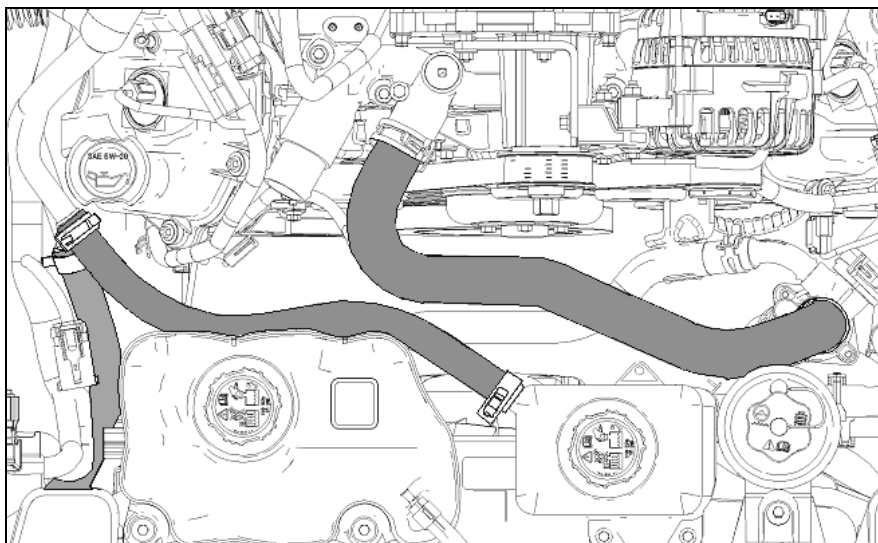

# ROUSH

THE **ART** OF PERFORMANCE ENGINEERING

PREMIUM FUEL REQUIRED

3. Reconnect the upper radiator hose to the intake manifold.

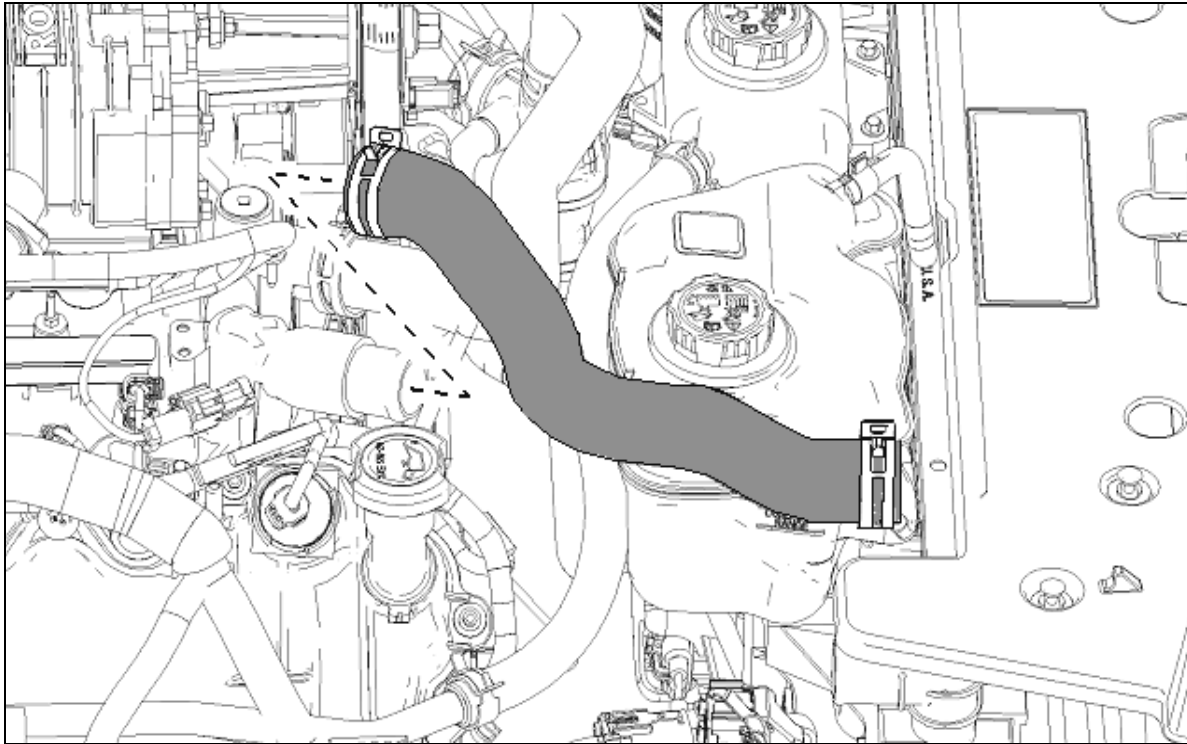

# ROUSH

THE ART OF PERFORMANCE ENGINEERING

PREMIUM FUEL REQUIRED

## Air Induction System

1. Install the airbox assembly by reversing the removal instructions. Torque retaining bolt to 8 – 12 Nm.
2. Install the throttle body end coupler (R07060029) with (1) #72 hose clamp from the Air Induction Kit. Install the hump hose (R07060030) on the airbox (round) end of the clean air tube using (1) #56 hose clamp. Place the #52 hose clamp over the end of the hump hose and the second #72 hose clamp over the throttle body end of the tube. Slide the hose ends into place and start the (2) M6 x 1.0 x 13mm support bracket bolts (N605771) from Hardware Kit B into the manifold. Position the couplers and tighten the clamps to 2 – 4Nm. Torque the support bracket bolts to 8 – 12 Nm. Plug in the MAF sensor.

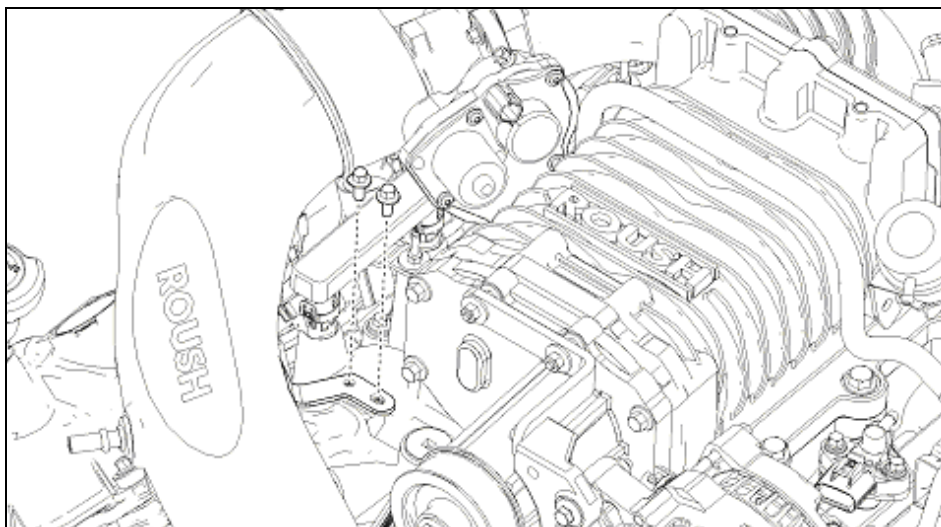

3. Connect the factory crankcase vent tube from the valve cover (near the oil fill) to the clean air tube. It is necessary to rotate the end fittings to achieve the desired routing illustrated below.

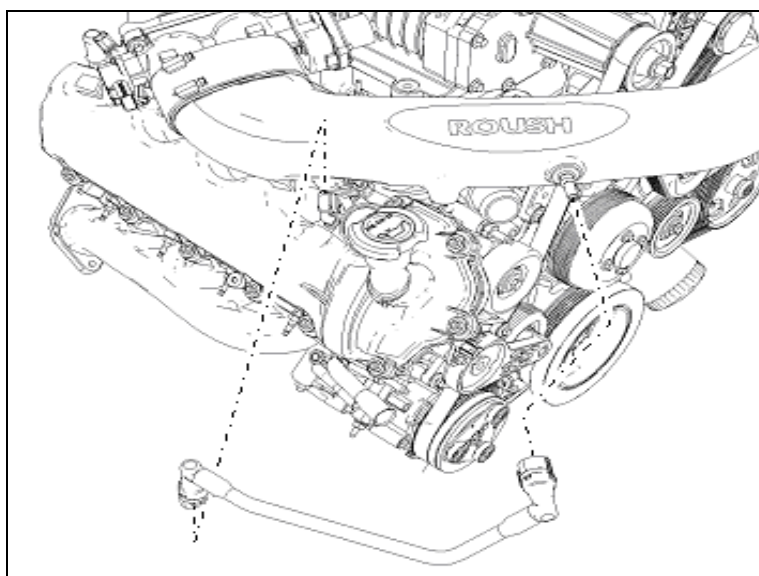

# ROUSH

THE ART OF PERFORMANCE ENGINEERING

PREMIUM FUEL REQUIRED

## Battery and Tray

1. Install the battery tray by reversing the removal instructions. Torque the battery tray bolts to 8 – 12Nm.
2. Place the battery in the tray and secure with battery hold down. Torque the battery hold down bolt to 8 – 12 Nm. Reinstall the heat protecting battery wrap over the battery.

## Vacuum System Connections

1. Connect the bubbler hose from the lower intake manifold to the throttle spacer (lower right 3/8" fitting) and secure 3/8" hose clamp from Hardware Kit I.

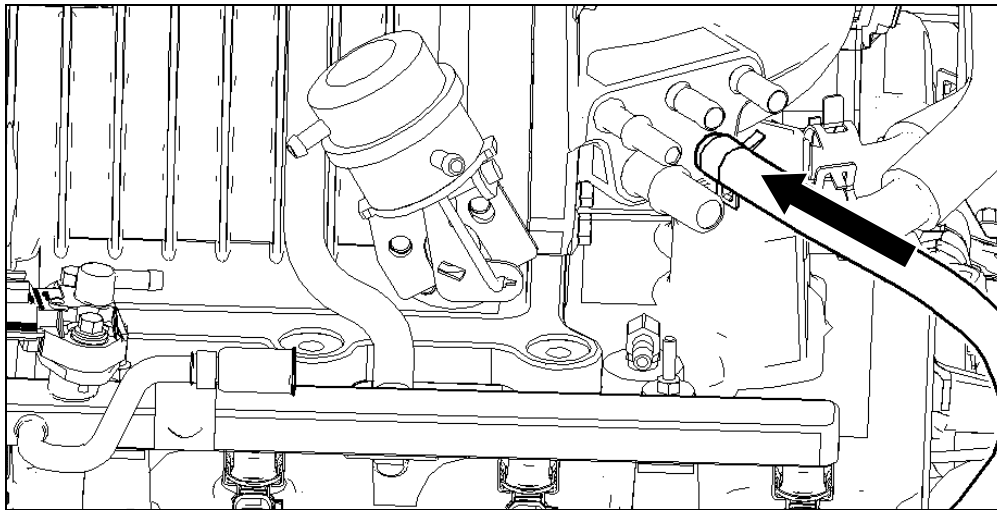

2. Remove the 1/8" IPTS hose from the stock brake booster hose (at the plastic junction point). Install the 1/8" take-off IPTS hose onto the IPTS (fuel rail sensor) and vacuum/boost 90 degree fitting on the manifold as shown below and insert the retaining clip onto the rear fuel rail stud bolt.

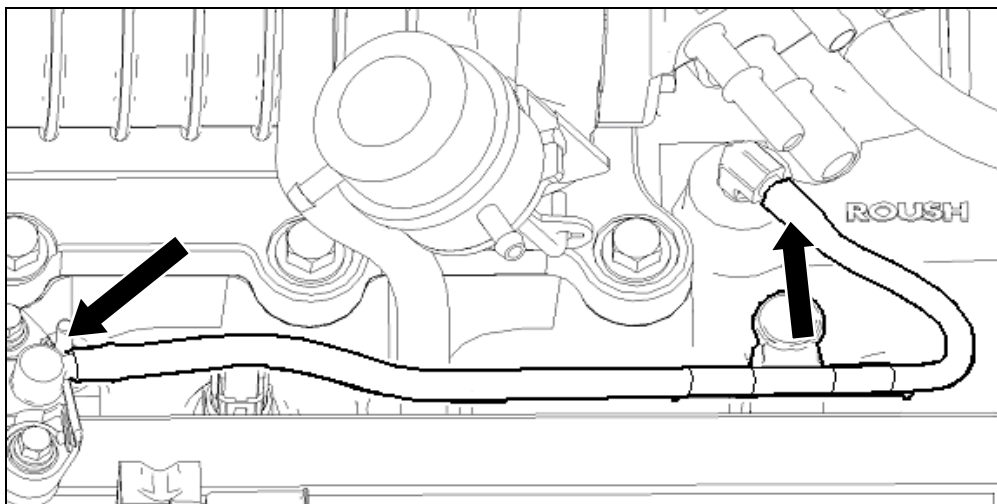

# ROUSH

THE **ART** OF PERFORMANCE ENGINEERING

PREMIUM FUEL REQUIRED

3. Install the new PCV purge tube (R07040006) from Hardware Kit E to the 5/8" SAE-style fitting on the throttle body spacer (lower left fitting). Reinstall the stock VMV hose to the upper front 3/8" SAE-style fitting.

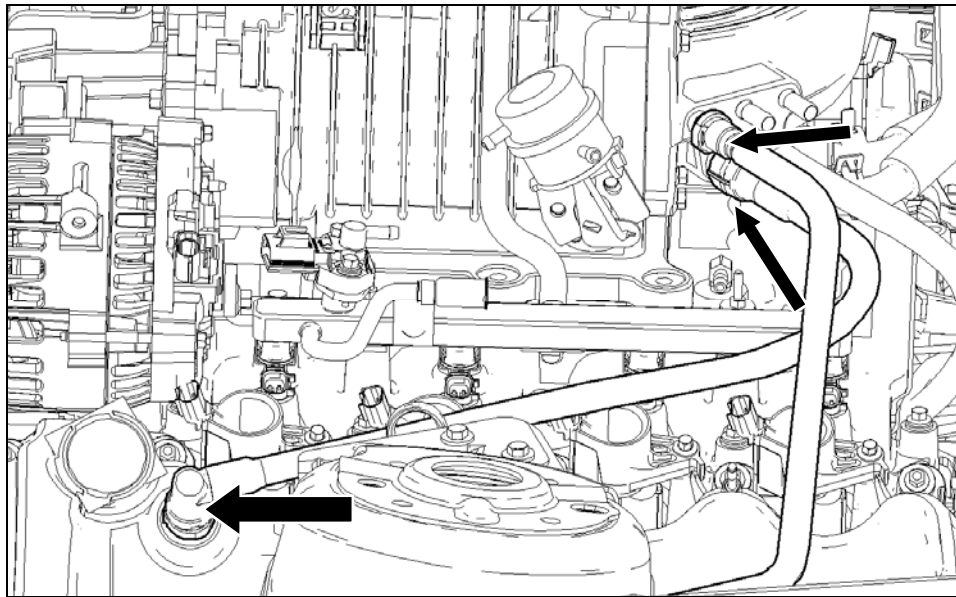

4. Install the fuel line to the fuel rail and secure using the safety clip.
5. Install the 3/8" Vacuum Cap (R07040040) over the rear-most nipple on the throttle Spacer.

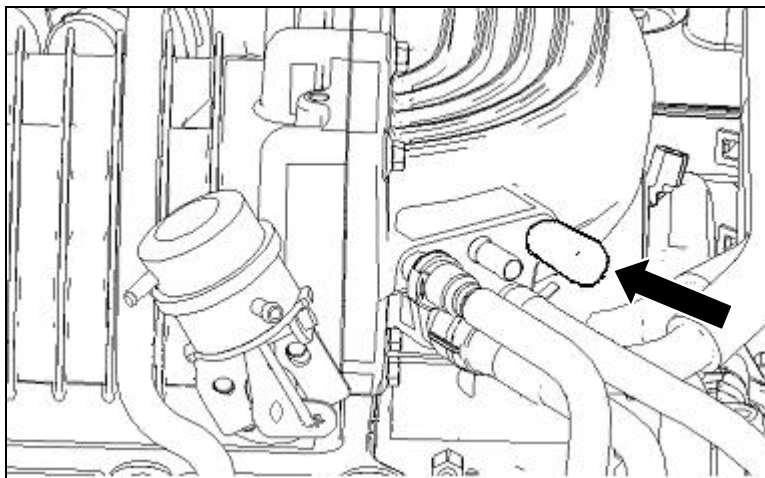

# ROUSH

THE ART OF PERFORMANCE ENGINEERING

PREMIUM FUEL REQUIRED

6. Connect the brake booster hose to the last open throttle body spacer fitting (top center port). Connect the supplied vacuum hose (R18140001) between the upper port on the bypass actuator and the open tee fitting on the brake hose.

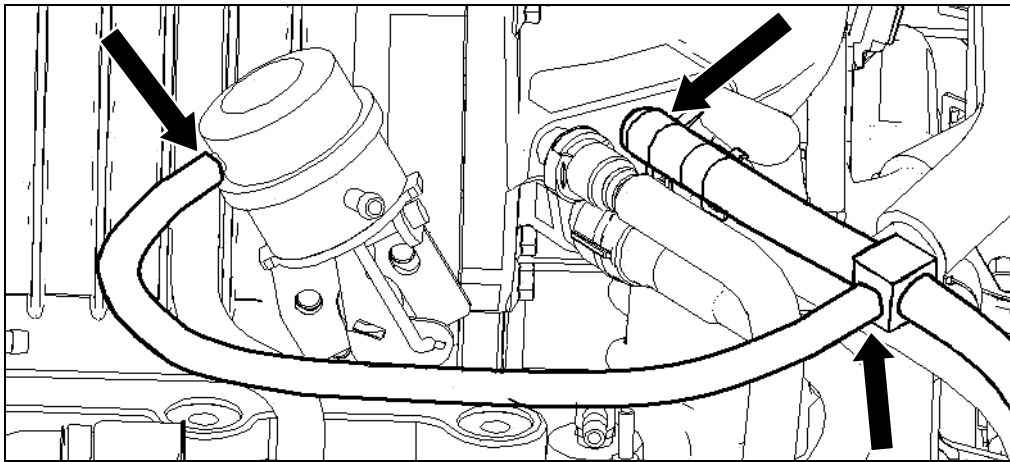

## **Coolant Fill and Final Assembly**

1. Fill the engine cooling system (using a proper G-05 coolant mixture) to the marked level on the radiator degas bottle.
2. Using the same coolant mixture, fill the intercooler system. The coolant should be approximately one inch below the top of the cap.

**Important:** Both coolant systems can trap a large amount of air. It is **very important** to verify that the air is purged and that coolant is flowing properly through both systems. ROUSH Performance recommends vacuum filling both systems to properly evacuate the trapped air.

3. Reinstall front bumper cover and inner fenders by reversing the removal instructions.
4. Reinstall the front wheels/tires.
5. Reinstall the newly flashed PCM by reversing the removal instructions.
6. Reinstall the battery connections. Connect the positive cable first. Connect the battery end of the alternator charge harness using the same stud and nut which retained the factory harness. Connect the negative cable to the battery.
7. Inspect all underhood wiring harnesses for potential interference issues. Use zip ties to safely position the harness away from any areas of concern.
8. Start the vehicle and check for fluid leaks, unusual noises, dash service lights, and unusual operation. If problems are detected, immediately stop the engine or vehicle, diagnose and repair the problem.

# ROUSH

THE **ART** OF PERFORMANCE ENGINEERING

PREMIUM FUEL REQUIRED

9. The “Premium Fuel” clear decal with white lettering (R07110004) is to be installed on the instrument cluster bezel, on the flat area below the small center gauges.

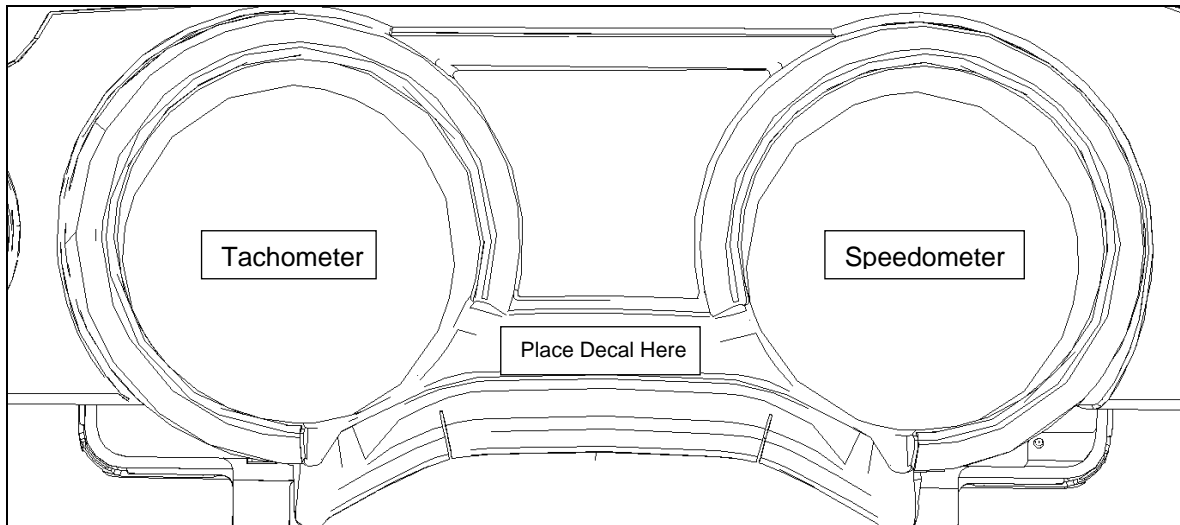

10. The “Premium Fuel” white decal with black lettering (R07110003) is to be placed on the lower half of the inside of the fuel filler door.

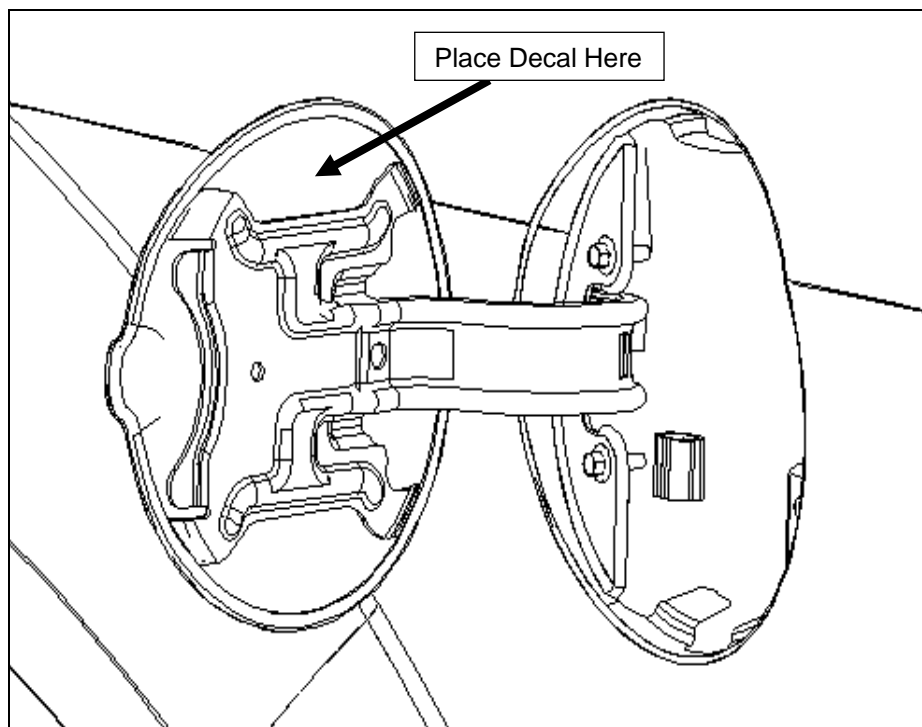

# ROUSH

THE **ART** OF PERFORMANCE ENGINEERING

PREMIUM FUEL REQUIRED

11. The Belt Routing Diagram (13106E072) is to be placed on the underside of the hood, on the driver side, opposite of the factory Vehicle Emission Control Information decal.

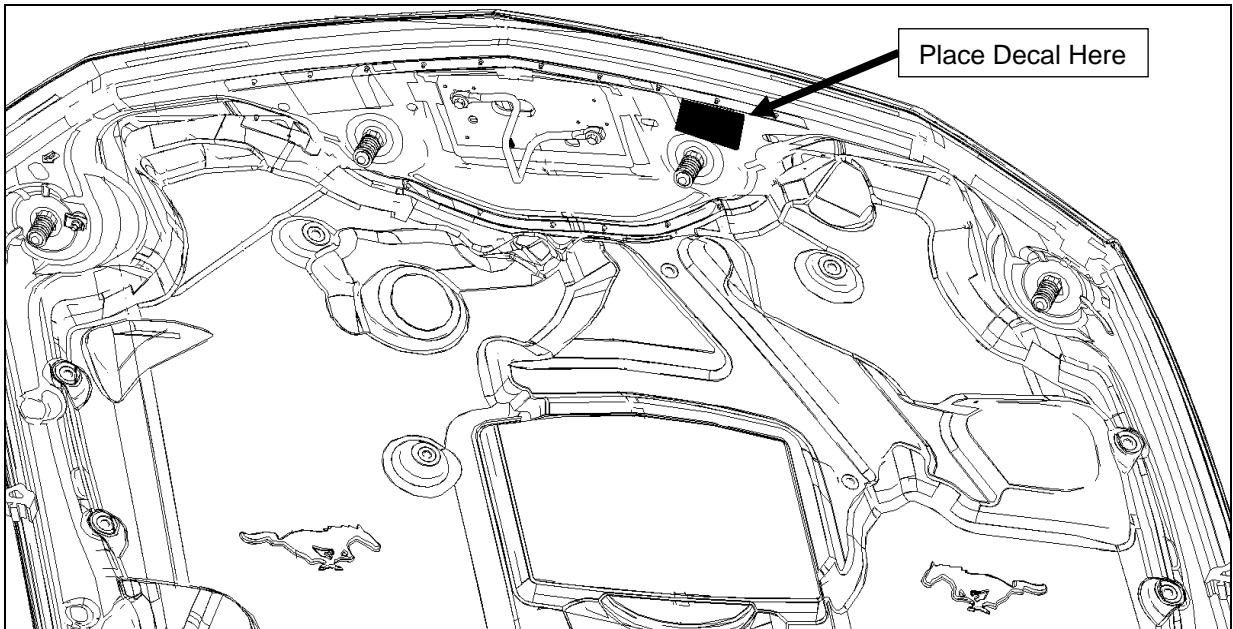

12. The E.O. Decal is to be placed on driver side strut tower, adjacent to the air filter assembly.

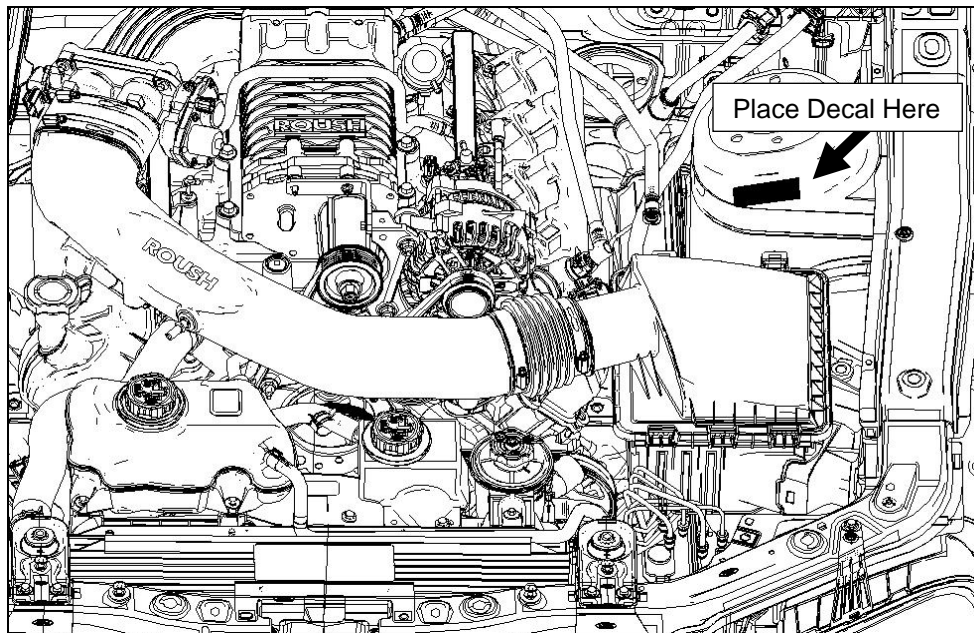



# ROUSH

THE **ART** OF PERFORMANCE ENGINEERING

PREMIUM FUEL REQUIRED

## **CARE AND MAINTENANCE OF OPTIONAL POLISHED ROUSHCHARGER**

The optional polished ROUSHCharger unit is uncoated, polished aluminum. As such, it will occasionally require polishing using a quality aluminum polishing compound to maintain its luster. Many “spray-on” aluminum cleaners contain caustic chemicals and may discolor or damage the finish of the ROUSHcharger and, as such, are not recommended.

## **WARRANTY**

All retail parts carry a 90-day warranty from the date of purchase. This warranty covers defects in materials or workmanship, and does not include (i) normal wear and tear, environmental conditions, improper installation; (ii) road hazards, misuse, abuse, neglect, accidents, collision, fire, theft, freezing, vandalism, riot, explosion, or objects striking the vehicle; (iii) misusing the vehicle, such as driving over curbs, overloading, racing, or using the vehicle as a stationary power source; (iv) altering, disassembling or modifying the parts; (v) defects caused or induced by failures, breakdowns, or damage by other parts, components or the vehicle; (vi) subjecting the parts to excessive moisture or water or any motor vehicle fluids (e.g.: oil, anti-freeze, battery acid, brake fluid, etc.); (vii) acts of God, natural disasters and other similar causes beyond the reasonable control of ROUSH; or (viii) application of chemicals that affect the parts. This Limited Warranty does not cover surface deterioration of paint, trim, and appearance items that result from use and/or exposure to the elements, such as stone chips, scratches, bird droppings, lightning, hail, windstorm, dings, dents, earthquake, road salt, tree sap, water or flood.

ROUSH SHALL NOT BE LIABLE TO REIMBURSE CUSTOMER/DEALER FOR INCIDENTAL OR CONSEQUENTIAL DAMAGES RESULTING FROM THE INSTALLATION OR USE OF ANY PRODUCT SOLD THROUGH THIS CATALOG OR ARISING OUT OF ANY BREACH OF WARRANTY. EXCEPT AS MAY BE STATED IN THIS CATALOG, ROUSH DISCLAIMS ALL EXPRESS AND IMPLIED WARRANTIES, INCLUDING THE WARRANTIES OF MERCHANTABILITY AND FITNESS FOR A PARTICULAR PURPOSE. IN NO EVENT SHALL ROUSH'S LIABILITY EXCEED THE PRICE PAID BY CUSTOMER/DEALER FOR PRODUCTS SOLD REGARDLESS IF ROUSH HAS BEEN ADVISED IN ADVANCE OF ANY POTENTIAL PROBLEM OR IF A CLAIM IS BASED ON CONTRACT, TORT, STRICT LIABILITY, PRODUCT LIABILITY OR OTHERWISE. SOME STATES DO NOT ALLOW THE EXCLUSION OR LIMITATION OF IMPLIED WARRANTIES OR THEIR DURATION, OR LIABILITY FOR INCIDENTAL OR CONSEQUENTIAL DAMAGES, SO THE ABOVE EXCLUSIONS OR LIMITATIONS MAY NOT APPLY.

This ROUSH Supercharger kit is designed and tested to function properly only on vehicles as they are equipped from the factory (completely stock powertrain). The use of aftermarket parts and equipment such as: cams, headers, nitrous oxide systems, other bolt-on performance parts, or any other performance parts not sold by, manufactured by, or approved of in writing by ROUSH, will result in powertrain and supercharger kit damage and will not be the responsibility of ROUSH in any way.

**If you have any questions or concerns please call 1-800-59-ROUSH.**