

BK055 INSTALLATION INSTRUCTIONS

INSTALLATION:

1. Lift vehicle and safely support with jack stands under the rear cradle.
2. Remove the wheels/tires to gain access to the work area.
3. Remove the lower shock bolts using a 15mm socket. **(IMAGE 1)**
4. Remove the bottom bolt on the vertical link using an 18mm socket. **(IMAGE 2)**
5. Remove the lower sway bar end link nut using a 15mm socket. **(IMAGE 3)**
6. Remove the outer bolt on the lower control arm using a 21mm socket. **(IMAGE 3)**
7. Remove both inner bolts on the lower control arm using a 24mm socket. **(IMAGE 4)**

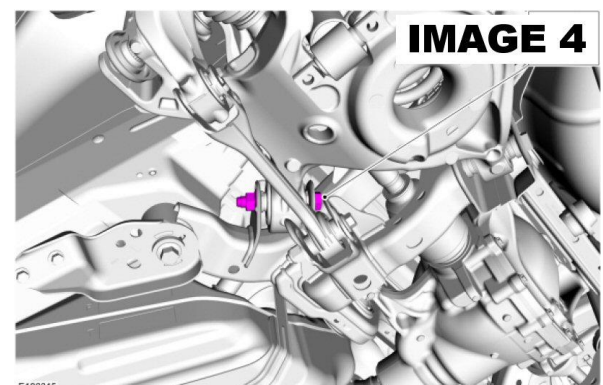

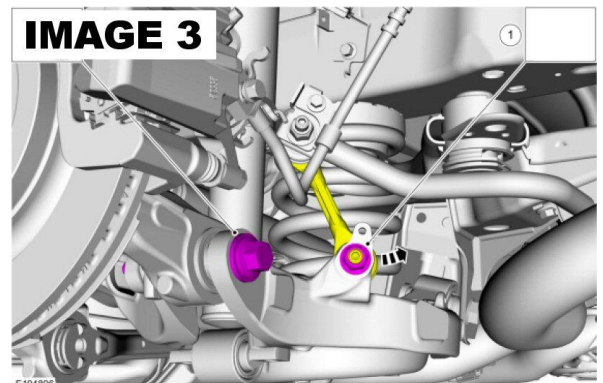
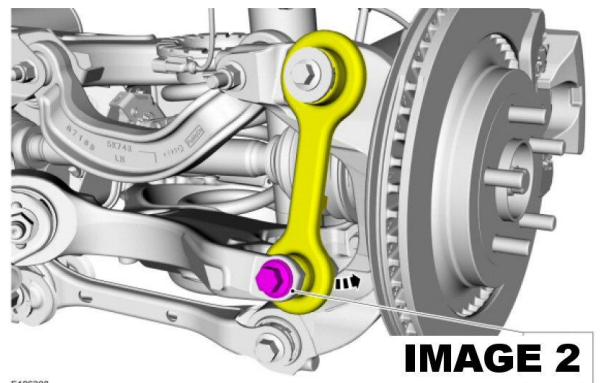
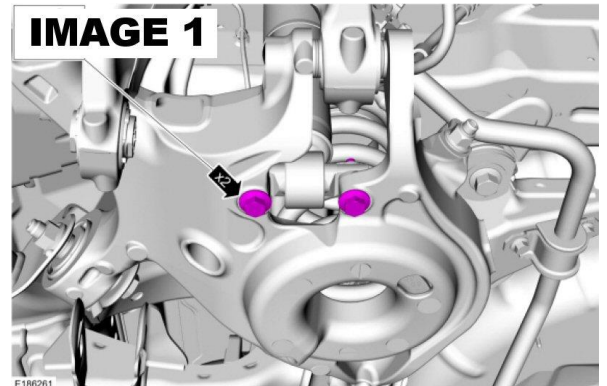

BK055 INSTALLATION INSTRUCTIONS

8. Lower the arm out of the mounts and set the spring aside. **(IMAGE 5)**
9. Using either a hydraulic press or the BMR tool BRT001, press out the factory bushing. If using the BMR tool, please follow the directions that come with the tool.
10. Once the factory bushing has been removed, smear some oil onto the inside of the bore then press the BMR bearing assembly into the control arm as shown in **IMAGE 6**. NOTE: the proper orientation of the BMR bearing assembly should have the flange of the bearing assembly on the outside of the control arm.
11. Once the BK055 is pressed into place, put the provided external snap ring onto the groove of the bearing assembly.
12. Repeat steps 3-11 for the other side.
13. Re-assemble the suspension using the following bolt torque recommendations:

Front Inner lower control arm bolts:	166 ft/lbs.
Rear Inner lower control arm bolts:	184 ft/lbs.
Outer control arm bolt:	203 ft/lbs.
Lower vertical link bolt:	129 ft/lbs.
Shock bolts:	35 ft/lbs.

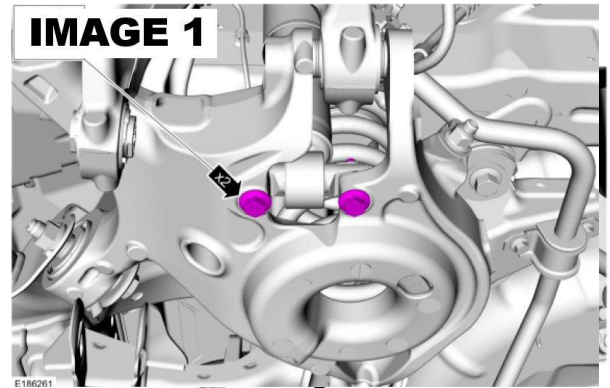

IMAGE 5



WWW.BMRSUSPENSION.COM

This product is an aftermarket accessory and not designed by the vehicles manufacturer for use on this vehicle. As such, Buyer assumes all risk of any damage caused to the vehicle or person during installation or use of this product.