



Part Number: M-5200-M8SC, M8TC, M8SB, M8TB
2015 5.0L Cat Back Exhaust System
INSTALLATION INSTRUCTIONS

Please visit www.fordracingparts.com for the most current instruction information

!!! PLEASE READ ALL OF THE FOLLOWING INSTRUCTIONS CAREFULLY PRIOR TO INSTALLATION.

AT ANY TIME YOU DO NOT UNDERSTAND THE INSTRUCTIONS, PLEASE CALL THE FORD RACING TECHLINE AT 1-800-367-3788 !!!

OVERVIEW:

The use of a floor hoist is recommended for this installation. If you do not have access to one, use a hydraulic floor jack and jack stands to raise the vehicle.

!! CAUTION: JACK STANDS MUST BE USED ON A LEVEL SURFACE AND BE SECURELY SEATED. FAILURE TO DO SO MAY RESULT IN PERSONAL INJURY OR VEHICLE DAMAGE !!

KIT INCLUDES:

<u>Item #</u>	<u>Qty:</u>	<u>Description</u>
	2	Muffler
	1	X-Pipe
	4	Clamp
	1	Left Hand Intermediate Pipe
	1	Right Hand Intermediate Pipe

via Mustang6G.com

Factory Ford shop manuals are available from Helm Publications, 1-800-782-4356



Part Number: M-5200-M8SC, M8TC, M8SB, M8TB
2015 5.0L Cat Back Exhaust System
INSTALLATION INSTRUCTIONS

Image of New Cat Back Exhaust System:

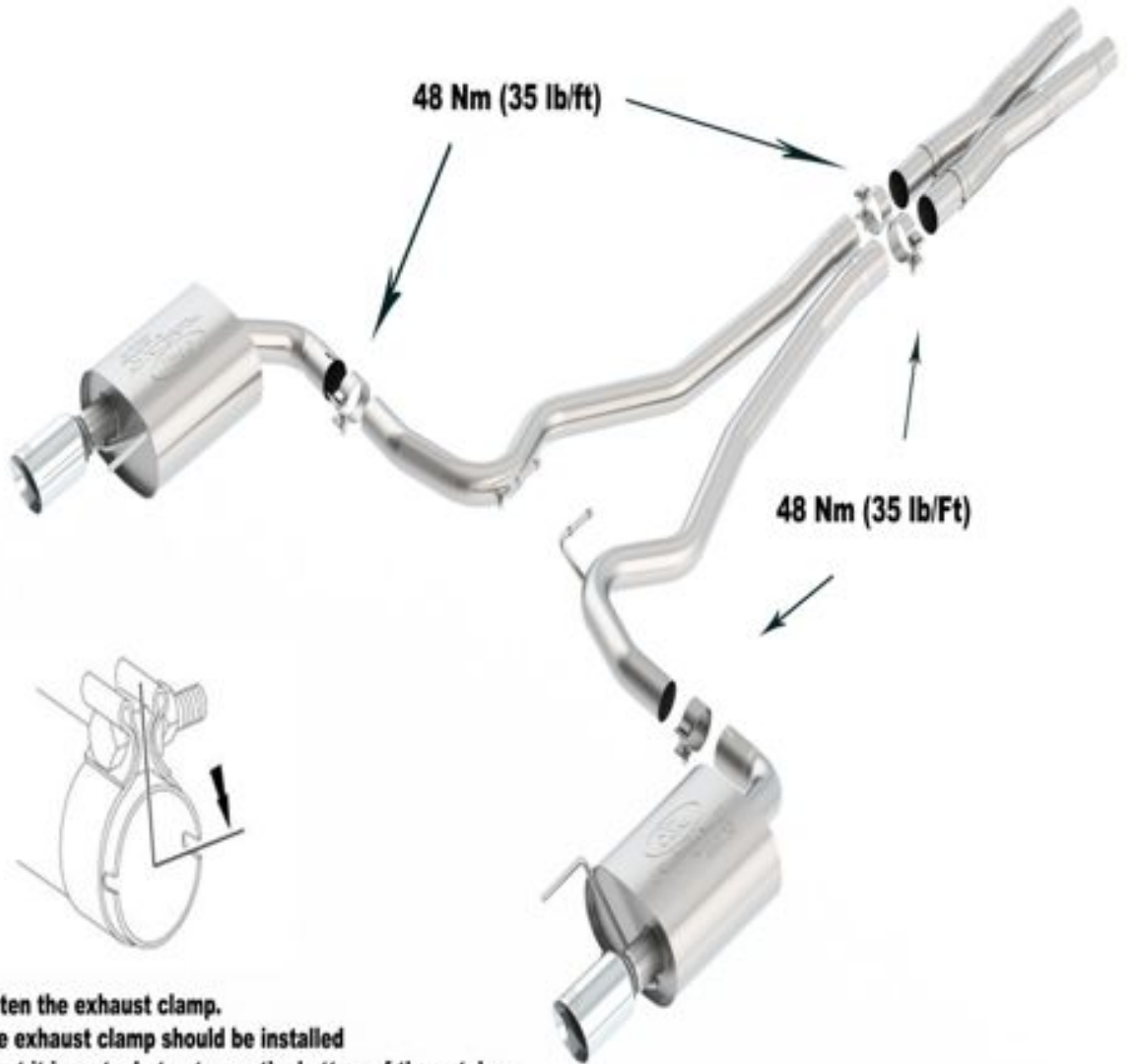

- Tighten the exhaust clamp.
- The exhaust clamp should be installed so that it is up to, but not over, the bottom of the notches.
 - Tighten to 48 Nm (35 lb-ft).

[via Mustang6G.com](http://Mustang6G.com)

Factory Ford shop manuals are available from Helm Publications, 1-800-782-4356

INSTALLATION INSTRUCTIONS:

STEP 1: Raise and support vehicle.

STEP 2: Spray penetrate on exhaust coupler bolts. Loosen all Exhaust coupler bolts.

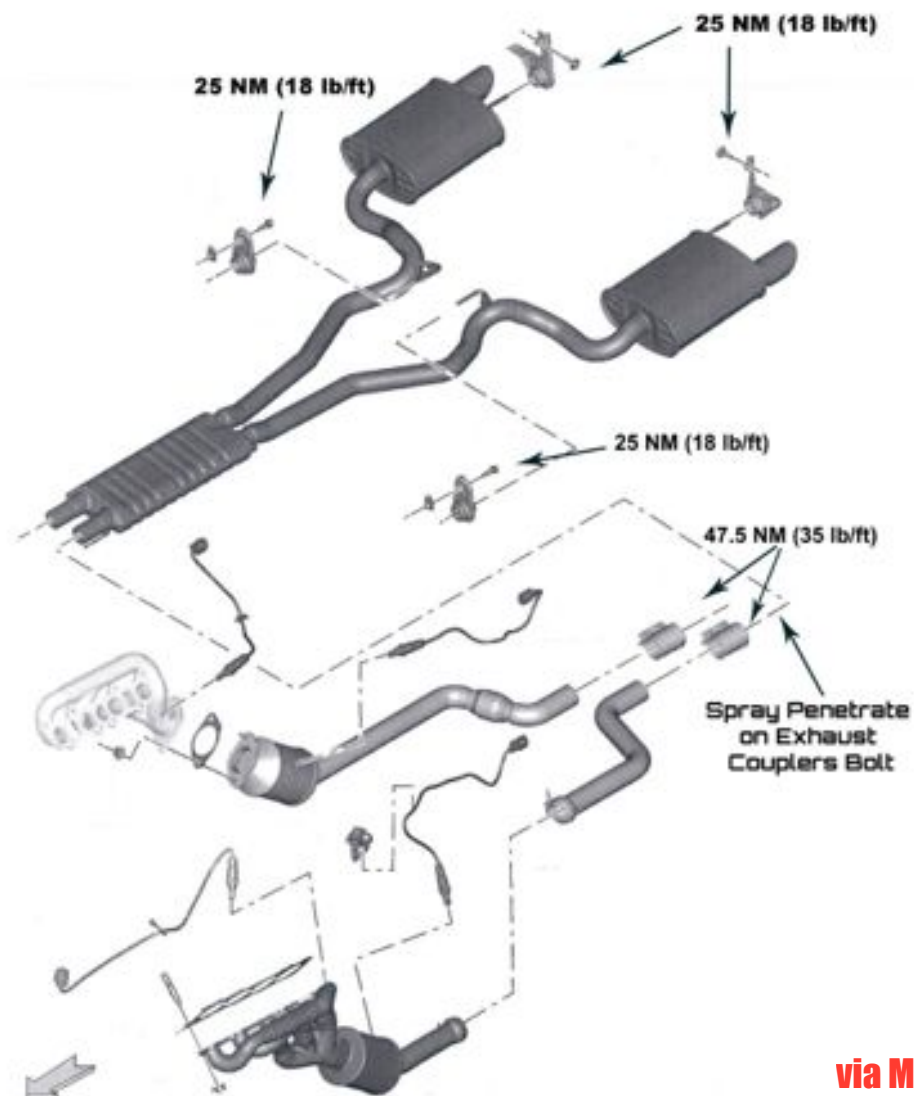

via Mustang6G.com

STEP 3: Using a 15mm socket loosen nuts on clamps (See Fig. 3).



Fig. 3

STEP 4: Using a 13mm socket remove bolts from exhaust hangers in rear Sub frame (See Fig. 4).



Fig. 4

via Mustang6G.com

STEP 5: After loosening exhaust clamps, slide clamps back on exhaust pipe releasing them from the down pipes. Remove clamps from resonator pipes and slide back onto down pipes. (See Fig. 5)



Fig. 5

Step 6: Allowing exhaust to hang down, remove rear mufflers from hangers by moving the exhaust system towards front of vehicle. (See Fig. 6)

Note: Have someone help with this step.

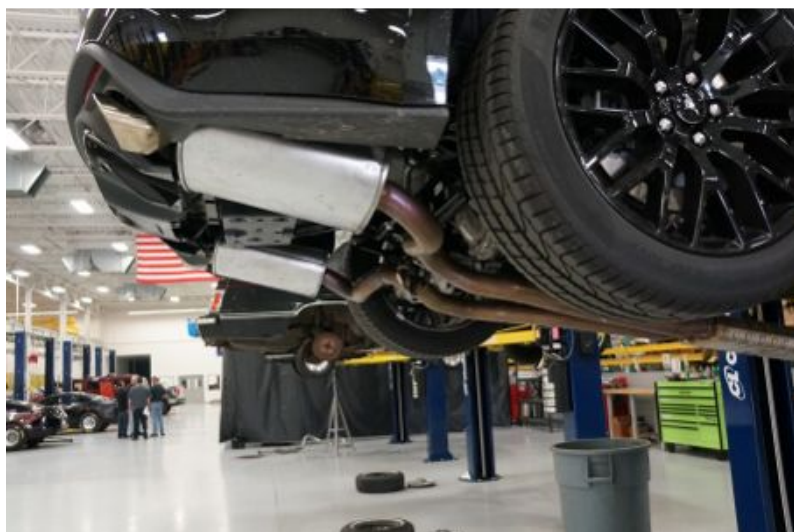

Fig. 6

via Mustang6G.com

Factory Ford shop manuals are available from Helm Publications, 1-800-782-4356

Step 7: Remove factory exhaust clamps from system and slide them onto flex pipes locking the lock tabs in place. (See Fig.7)



Fig. 7

Step 8: Install new x-pipe onto clamps and tighten to 47.5nm (35 lb-ft) (See Fig. 8)



Fig. 8

via Mustang6G.com

Step 9: Install factory removed hangers onto under axle pipes. (See Fig 9)



Fig. 9

Step 10: Install supplied clamps onto x-pipe side of under axle pipes, slide pipes/clamps onto x-pipe. Using a 13mm socket install bolts in exhaust hangers in rear Sub frame. (See fig. 10)



Fig. 10

Step 11: Using a 13mm socket tighten bolts to 25 nm (18 lb-ft) in rear Sub frame exhaust hangers. (See fig. 11)



Fig. 11

Step 12: Using a 15mm socket tighten nuts on x-pipe clamps 47.5 nm (35 lb-ft) (See Fig. 12).



Fig. 12

Step 13: Install supplied clamps onto new muffler, slide muffler hangers into factory exhaust hangers. Next slide the muffler over the under axle pipes, center muffler in rear bumper opening and tighten clamps to 48 nm (35 lb-ft) (See Fig. 13)



Fig. 13

via Mustang6G.com

Factory Ford shop manuals are available from Helm Publications, 1-800-782-4356



Part Number: M-5200-M8SC, M8TC, M8SB, M8TB
2015 5.0L Cat Back Exhaust System
INSTALLATION INSTRUCTIONS

Step 14: Check all fasteners for proper torque.

Step 15: Check alignment of mufflers in rear bumper cover.



Step 16: Lower vehicle and road test.