



M-9603-GTB 85 mm Cold Air Kit w/Premium Cal. for 4.6L 3V V8 Mustang INSTALLATION INSTRUCTIONS

NO PART OF THIS DOCUMENT MAY BE REPRODUCED WITHOUT PRIOR AGREEMENT AND WRITTEN PERMISSION OF FORD RACING PERFORMANCE PARTS.

Please contact the Techline for the most current instruction information 800-367-3788.

!!! PLEASE READ THE FOLLOWING INSTRUCTIONS CAREFULLY PRIOR TO INSTALLATION !!!

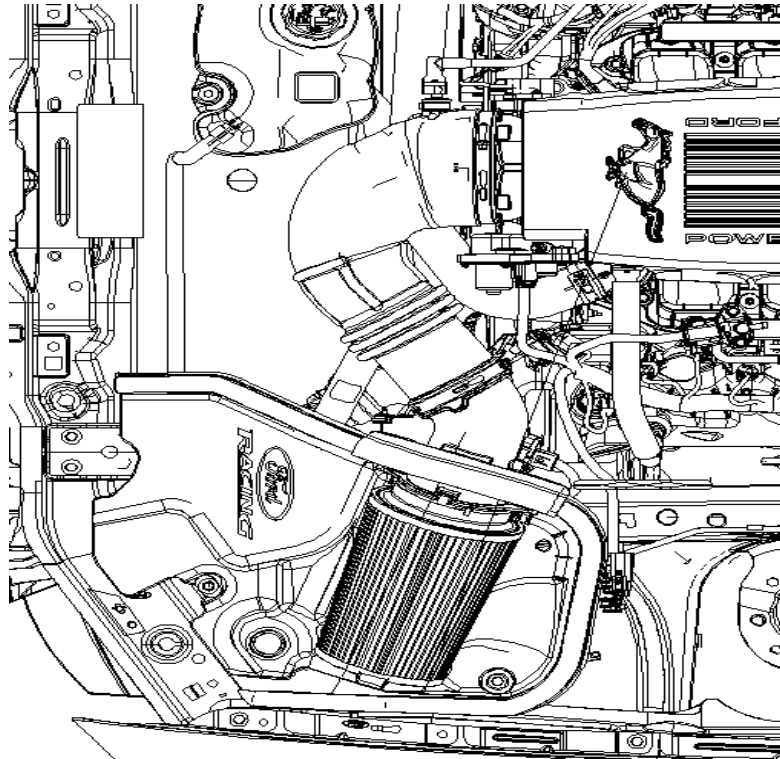

OVERVIEW:

This kit is designed for use on 4.6L 3V V8 Ford Mustang.

NOTES:

- **BEFORE INSTALLING** the Cold Air Kit, please register this product by following the steps listed on the voucher card included with the kit. **PRODUCT REGISTRATION IS REQUIRED** to receive the ProCal flash tool used to recalibrate the vehicle PCM. Operating the engine without the PCM recalibration will result in engine damage or failure and will **VOID THE WARRANTY**.
- Please read the installation instructions carefully and verify that all items are present. If you are missing hardware or have any questions, please contact the Ford Racing Techline at 1-800-367-3788.
- Premium fuel (91 octane or higher) is required to prevent “spark knock” or detonation under certain operating conditions. The use of fuel additives (i.e., octane boosters) is not recommended. There is a possibility that these chemicals can damage your engine and cause drivability issues with your vehicle.

Techline 800-367-3788

Factory Ford shop manuals are available from Helm Publications, 1-800-782-4356

IS-1850-0161



M-9603-GTB 85 mm Cold Air Kit w/Premium Cal. for 4.6L 3V V8 Mustang INSTALLATION INSTRUCTIONS

NO PART OF THIS DOCUMENT MAY BE REPRODUCED WITHOUT PRIOR AGREEMENT AND WRITTEN PERMISSION OF FORD RACING PERFORMANCE PARTS.

KIT INCLUDES:

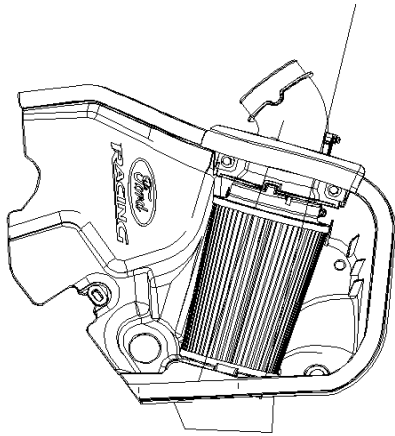

1

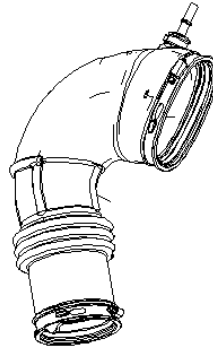

2

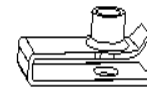

3



4

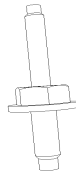

5



6



7

<u>Item #</u>	<u>Qty</u>	<u>Part Number</u>	<u>Description</u>
1	1		Air Intake Bucket Assembly
2	1		Clean Air Tube Assembly
3	1	W710868-S439	U-Nut Upper
4	1	N802981-S	Plug
5	1	W713891-S439	Mounting Stud Upper
6	1	N620480-S437	Nut Upper
7	1		E.O. Label (D-598-2)
8	2	W709287S300	Bolt 4mm X .7(not shown)

Techline 800-367-3788

Factory Ford shop manuals are available from Helm Publications, 1-800-782-4356

IS-1850-0161



M-9603-GTB 85 mm Cold Air Kit w/Premium Cal. for 4.6L 3V V8 Mustang INSTALLATION INSTRUCTIONS

NO PART OF THIS DOCUMENT MAY BE REPRODUCED WITHOUT PRIOR AGREEMENT AND WRITTEN PERMISSION OF FORD RACING PERFORMANCE PARTS.



9

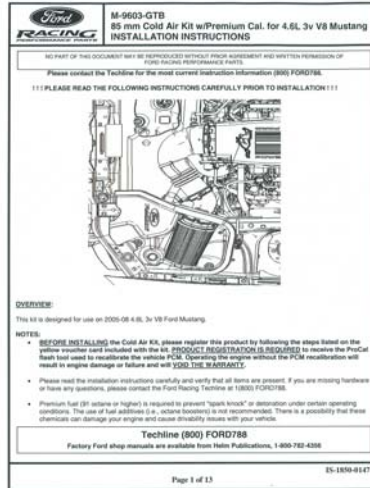

10



11

(photo may vary)

Item #	Qty	Part Number	Description
9	1	R07140004	Registration/Warranty Voucher
10	1	IS-1850-0147	Installation Instructions
11	0**	NPN	ProCal Flash Tool

The ProCal Flash Tool is **NOT included in the kit. Once you **register** the product and **request** the ProCal tool, one will be shipped to you.

EQUIPMENT AND SUPPLIES REQUIRED:

- Metric ratchet / extension / socket set
- Torque wrench
- T-20 Torx Bit screwdriver or socket

Techline 800-367-3788

Factory Ford shop manuals are available from Helm Publications, 1-800-782-4356

IS-1850-0161



M-9603-GTB 85 mm Cold Air Kit w/Premium Cal. for 4.6L 3V V8 Mustang INSTALLATION INSTRUCTIONS

NO PART OF THIS DOCUMENT MAY BE REPRODUCED WITHOUT PRIOR AGREEMENT AND WRITTEN PERMISSION OF FORD RACING PERFORMANCE PARTS.

SAFETY PRECAUTIONS:

!!! STOP! CAREFULLY READ THE IMPORTANT SAFETY PRECAUTIONS AND WARNINGS BEFORE PROCEEDING WITH THE INSTALLATION !!!

Appropriate disassembly and assembly methods and procedures are essential to ensure the personal safety of the individual performing the kit installation. Improper installation due to the failure to correctly follow these instructions could cause personal injury or death. Read each step of the installation instructions carefully before starting the installation.

- Always wear safety glasses for eye protection.
- Place ignition switch in the OFF position.
- Always apply the parking brake when working on the vehicle.
- Block the front and rear tire surfaces to prevent unexpected vehicle movement.
- Operate the engine only in well-ventilated areas to avoid exposure to carbon monoxide.
- Do not smoke or use flammable items near or around the fuel system.
- Use chemicals and cleaners only in well-ventilated areas.
- Batteries can produce explosive hydrogen gas, which can cause personal injury. Therefore, do not allow flames, sparks or flammable sources to come near the battery.
- Keep hands and any other objects away from the radiator fan blades.
- Keep yourself and your clothing away from moving parts when the engine is running.
- Do not wear loose clothing or jewelry which can be caught in rotating or moving parts.

DISASSEMBLY INSTRUCTIONS:

The following section will guide you through the disassembly of the stock components. Special care should be taken to label fasteners and parts that are taken off during this procedure since many will be reused.

STEP 1: Cover both fenders with fender covers to protect the vehicle finish.

STEP 2: Disconnect the negative (-) and positive (+) connections to the battery. Cover the positive (+) battery terminal to prevent any contact.

Techline 800-367-3788

Factory Ford shop manuals are available from Helm Publications, 1-800-782-4356



M-9603-GTB 85 mm Cold Air Kit w/Premium Cal. for 4.6L 3V V8 Mustang INSTALLATION INSTRUCTIONS

NO PART OF THIS DOCUMENT MAY BE REPRODUCED WITHOUT PRIOR AGREEMENT AND WRITTEN PERMISSION OF FORD RACING PERFORMANCE PARTS.

STEP 3: Disconnect the MAF wiring from the airbox. Loosen the clean air tube clamps and disconnect the clean air tube from the airbox and throttle body (See Fig. 1).

STEP 4: Disconnect PCV tube and remove clean air tube (See Fig. 1).

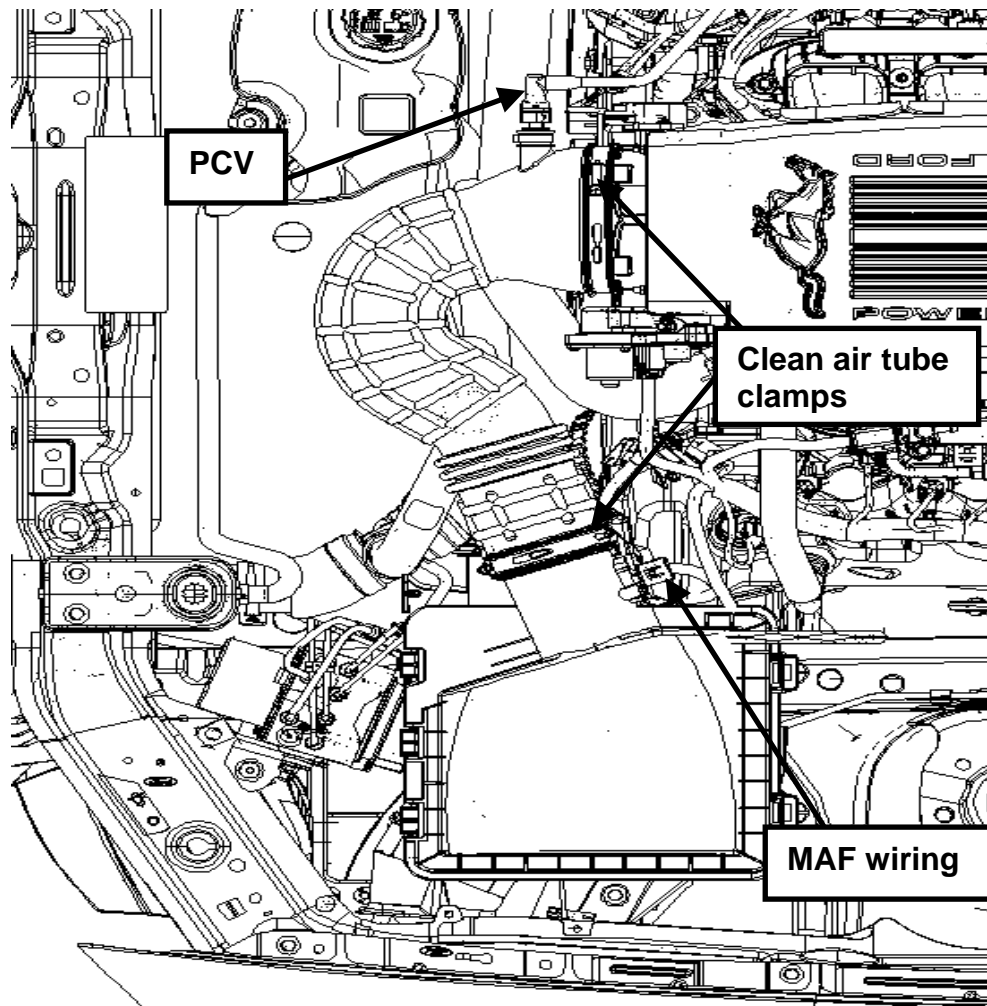

Fig. 1

Techline 800-367-3788

Factory Ford shop manuals are available from Helm Publications, 1-800-782-4356

IS-1850-0161



M-9603-GTB
85 mm Cold Air Kit w/Premium Cal. for 4.6L 3V V8 Mustang
INSTALLATION INSTRUCTIONS

NO PART OF THIS DOCUMENT MAY BE REPRODUCED WITHOUT PRIOR AGREEMENT AND WRITTEN PERMISSION OF FORD RACING PERFORMANCE PARTS.

STEP 5: Remove the airbox retainer bolt and airbox from vehicle (See Fig. 2).

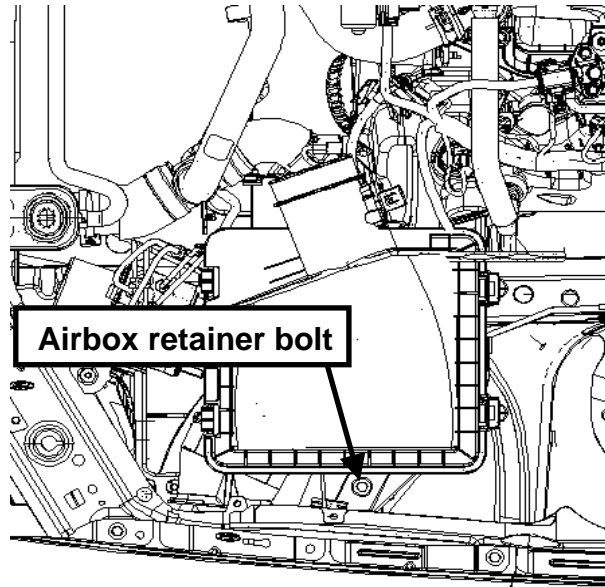

Fig. 2

STEP 6: Remove MAF bolts and MAF from the factory airbox (See Fig. 3).

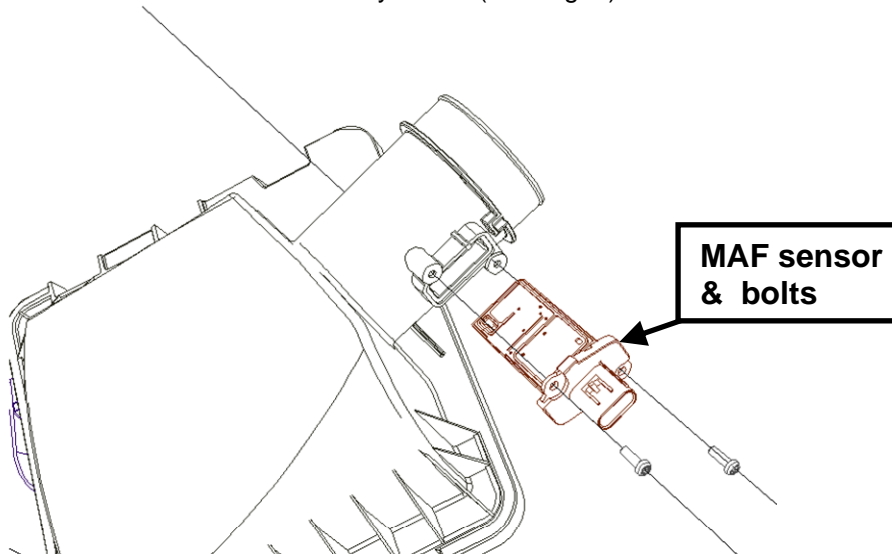

Fig. 3

Techline 800-367-3788

Factory Ford shop manuals are available from Helm Publications, 1-800-782-4356



M-9603-GTB 85 mm Cold Air Kit w/Premium Cal. for 4.6L 3V V8 Mustang INSTALLATION INSTRUCTIONS

NO PART OF THIS DOCUMENT MAY BE REPRODUCED WITHOUT PRIOR AGREEMENT AND WRITTEN PERMISSION OF FORD RACING PERFORMANCE PARTS.

INSTALLATION INSTRUCTIONS:

The following section will guide you through the installation of this kit. If you need to stop during any part of the installation, make sure you cover the clean air tube inlet to prevent foreign material from contaminating your engine.

STEP 1: Install the MAF sensor using the bolts 4mm x .7 Item #8 into the new air intake bucket assembly. Torque the bolts to 4 Nm (35 lb-in) (See Fig. 4).

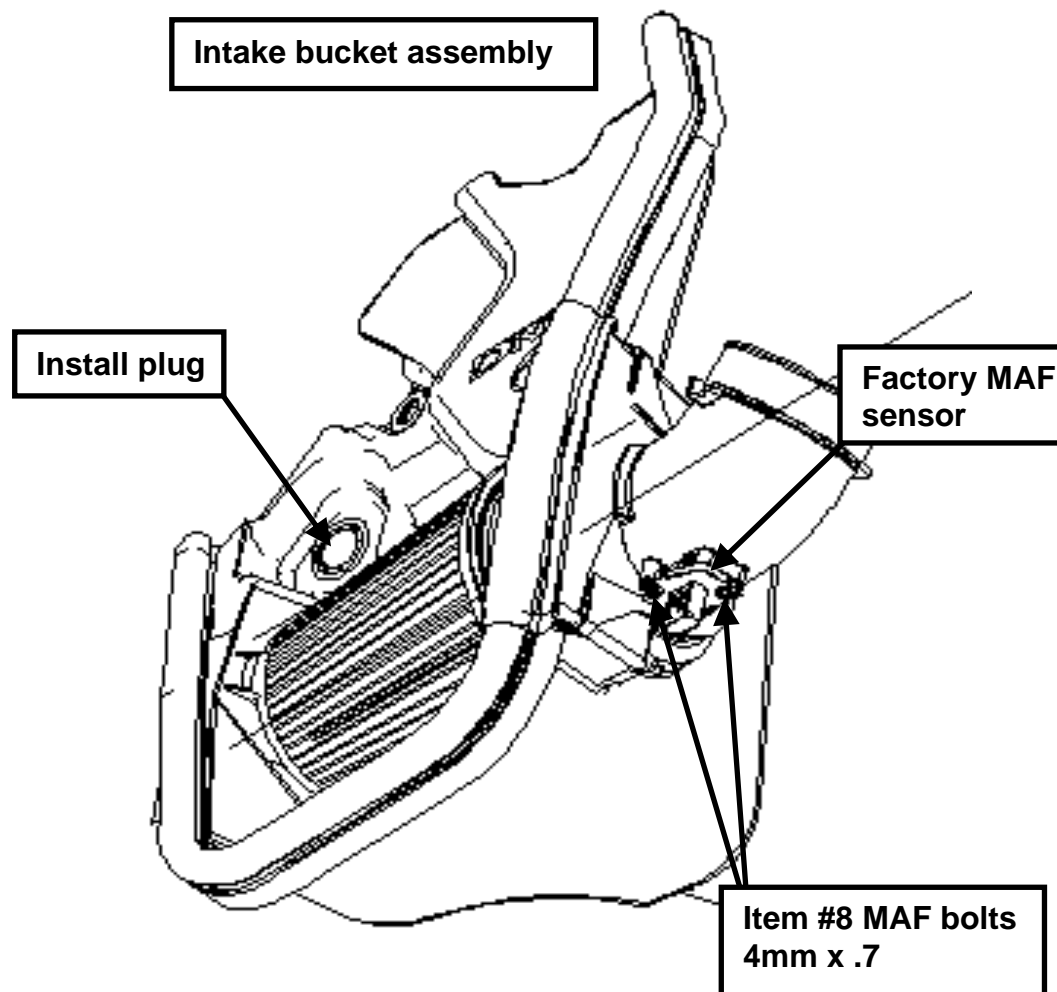

Fig. 4

Techline 800-367-3788

Factory Ford shop manuals are available from Helm Publications, 1-800-782-4356

IS-1850-0161



M-9603-GTB 85 mm Cold Air Kit w/Premium Cal. for 4.6L 3V V8 Mustang INSTALLATION INSTRUCTIONS

NO PART OF THIS DOCUMENT MAY BE REPRODUCED WITHOUT PRIOR AGREEMENT AND WRITTEN PERMISSION OF FORD RACING PERFORMANCE PARTS.

STEP 2: Locate the ABS module bracket and remove the bolt shown below (Fig. 5). If vehicle is non-ABS, install U-nut in this location.

STEP 3: Install stud in this location and torque to 25 Nm (221 lb-in) (See Fig. 5).

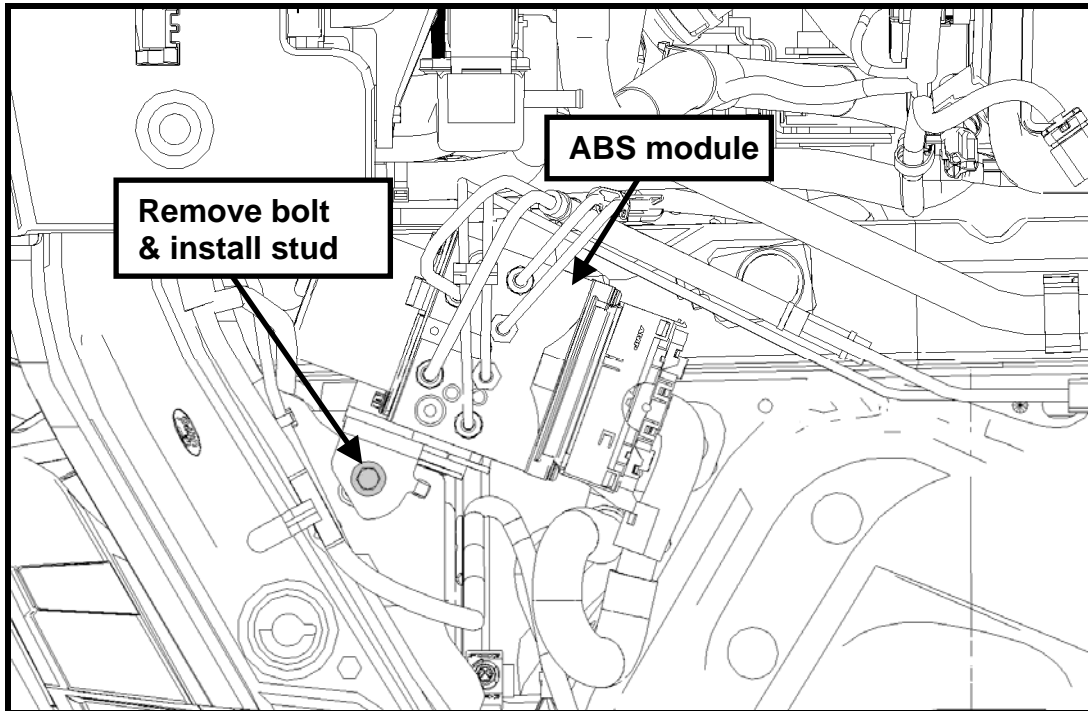

Fig. 5

Techline 800-367-3788

Factory Ford shop manuals are available from Helm Publications, 1-800-782-4356



M-9603-GTB 85 mm Cold Air Kit w/Premium Cal. for 4.6L 3V V8 Mustang INSTALLATION INSTRUCTIONS

NO PART OF THIS DOCUMENT MAY BE REPRODUCED WITHOUT PRIOR AGREEMENT AND WRITTEN PERMISSION OF FORD RACING PERFORMANCE PARTS.

- STEP 4:** Lower the complete airbox assembly into the vehicle using the two pegs as guides into the rubber grommets. Use the take-off airbox bolt and newly supplied nut to secure the airbox in the vehicle. Torque the M6 bolt to 8 Nm (70 lb-in), and the nut to 8 Nm (70 lb-in) (See Fig. 6).

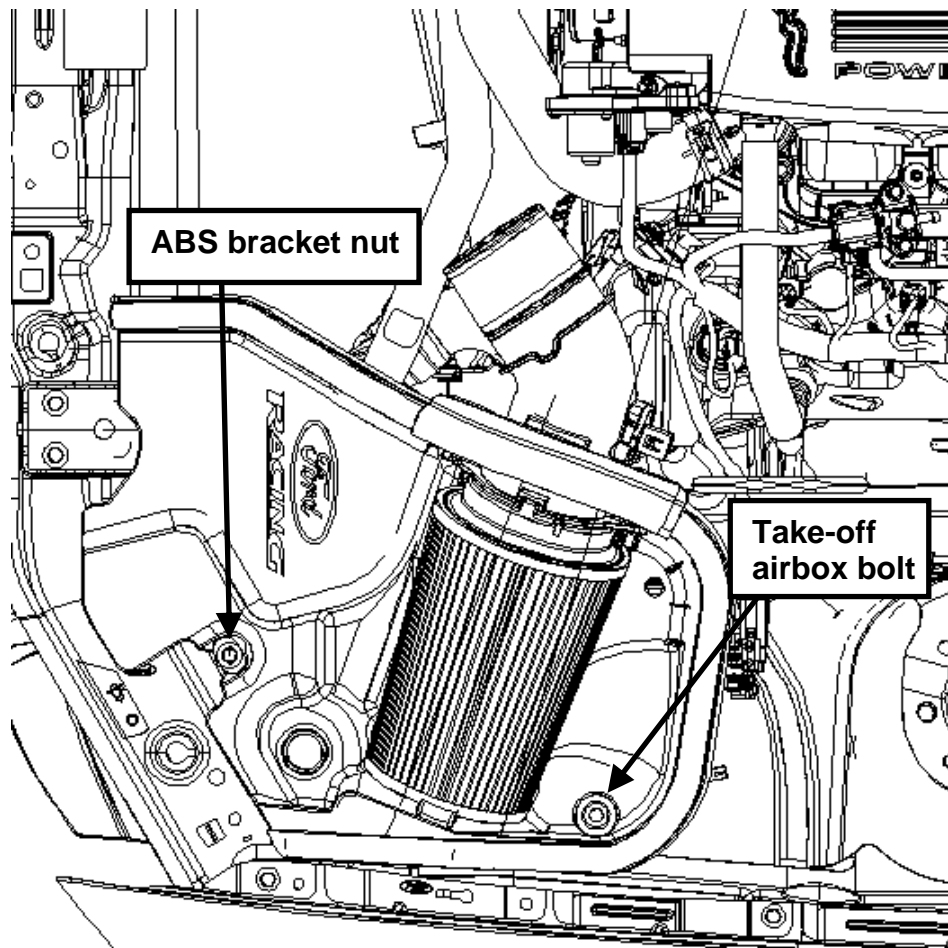

Fig. 6

Techline 800-367-3788

Factory Ford shop manuals are available from Helm Publications, 1-800-782-4356



M-9603-GTB 85 mm Cold Air Kit w/Premium Cal. for 4.6L 3V V8 Mustang INSTALLATION INSTRUCTIONS

NO PART OF THIS DOCUMENT MAY BE REPRODUCED WITHOUT PRIOR AGREEMENT AND WRITTEN PERMISSION OF FORD RACING PERFORMANCE PARTS.

STEP 5: Install the new rubber clean air tube onto the throttle body and air intake bucket assembly. Tighten the worm drive clamps and torque to 3 Nm (26 lb-in). Re-install the MAF electrical connector onto the MAF sensor and reconnect the PCV hose (See Fig. 7).

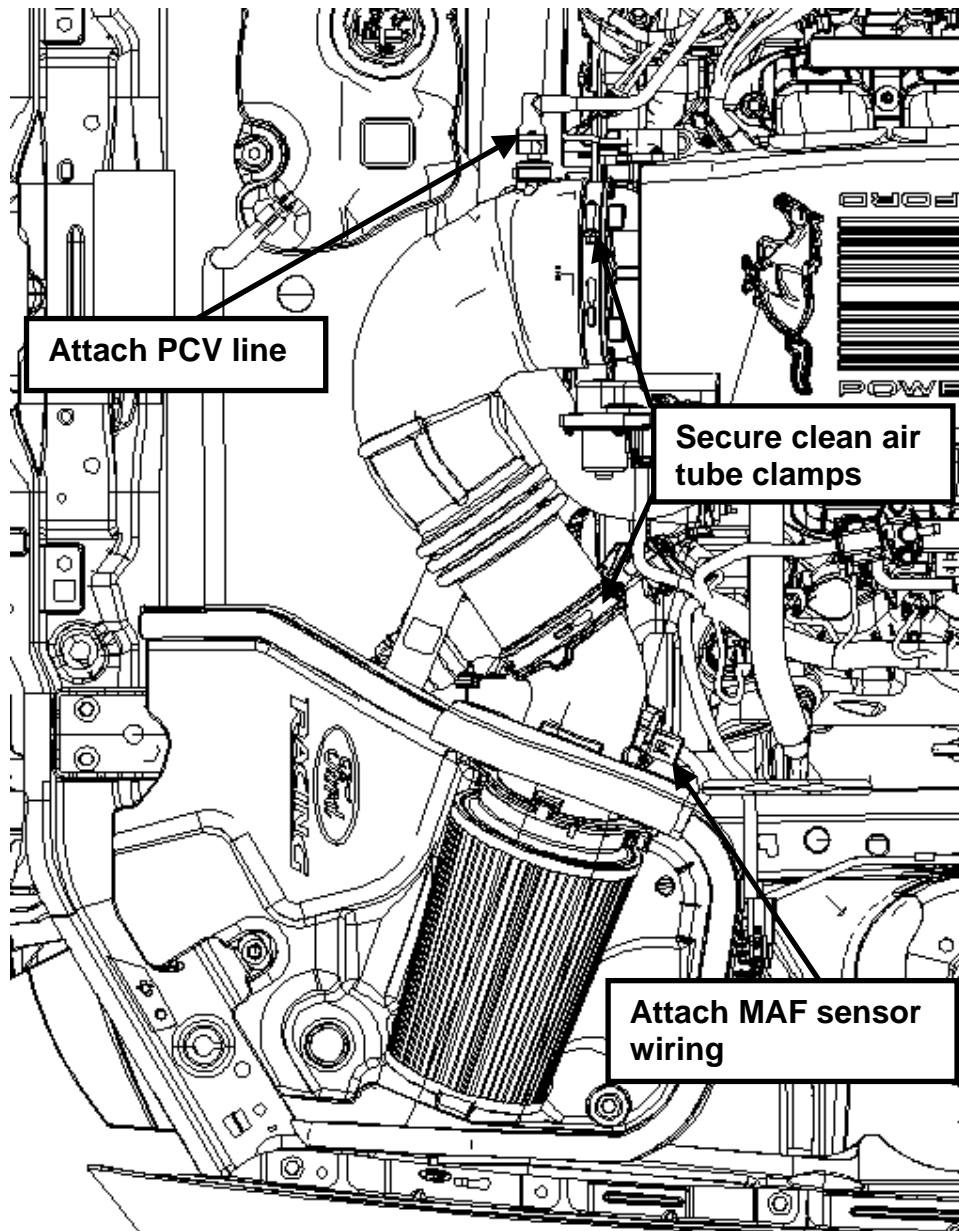

Fig. 7

Techline 800-367-3788

Factory Ford shop manuals are available from Helm Publications, 1-800-782-4356

IS-1850-0161



M-9603-GTB
85 mm Cold Air Kit w/Premium Cal. for 4.6L 3V V8 Mustang
INSTALLATION INSTRUCTIONS

NO PART OF THIS DOCUMENT MAY BE REPRODUCED WITHOUT PRIOR AGREEMENT AND WRITTEN PERMISSION OF FORD RACING PERFORMANCE PARTS.

STEP 6: Re-install the battery connections. Connect the positive cable to the battery first, then the negative cable. Check to insure that the battery is fully charged (12.0V to 14.5V).

STEP 7: **VERY IMPORTANT!!! DO NOT RUN YOUR VEHICLE UNTIL THE PCM HAS BEEN REFLASHED WITH THE PRO CAL TOOL!!! FOLLOW THE INSTRUCTIONS THAT COME WITH THE PRO CAL TOOL!!!**

If there are any questions or concerns, please call the Ford Racing Techline at 1-800-367-3788.

STEP 8: After PCM has been successfully programmed (flashed), check for unusual noises, dash service lights and unusual operation. If problems are detected, immediately stop the engine or vehicle and diagnose and repair the problem.

FORD RACING LIMITED WARRANTY

A Limited Warranty is valid only when proof of purchase is registered by the installing Ford dealer by contacting the Ford Racing Call Center at 1-800-367-3788. For warranty details please visit the www.fordracingparts.com website.

Techline 800-367-3788

Factory Ford shop manuals are available from Helm Publications, 1-800-782-4356