

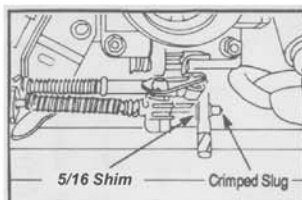

performance automatic
instructions

PA53301 AOD STREET/STRIP VALVE BODY

1. Check the TV pressure. The TV pressure at idle should read 0-3 psi.
2. Make sure throttle linkage is at stop.
3. Hook up pressure gauge to TV pressure port in case.
4. Have someone start the vehicle, put his foot on brake, and put the vehicle in drive. The TV pressure should be reading 0-3 psi.
- 5a. Put a 5/16" drill bit, shim or allen wrench between the throttle linkage and stop. TV pressure should be reading 25-30 psi.
- 5b. Insert adjustment tool between cable end and plastic pivot. Depress the cable lock and adjust in or out until you have a TV pressure reading of 25-30 psi at idle.
6. Adjust linkage to get correct pressure of 25-30 psi.

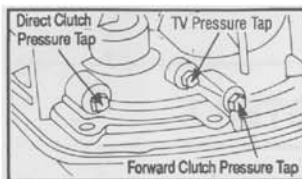

Injection

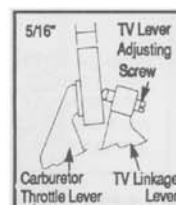

CARB



Read instructions completely before attempting installation. This valve body should be installed by a qualified transmission technician. If you are unfamiliar with any of the operations or terms found in these instructions, you should take your transmission to a qualified race transmission shop. Improper installation may result in property damage or personal injury.

1. Drain transmission oil by removing the back oil pan bolts and work towards the front, slowly.

2. Remove the 3 filter bolts and 24 valve body-attaching bolts and remove valve body by pulling straight down. Check to make sure all of the valve body to case gasket is removed from transmission case.

3. Install valve body into transmission carefully. You must engage selector lever into manual valve (Figure 1).

4. Tighten valve body bolts finger tight. Check for free operation of shifter linkage if accessible. Tighten valve body bolts to 80-120 in. lbs. Install filter reusing original square gasket, see figure A. Make sure rubber grommet is installed into filter.

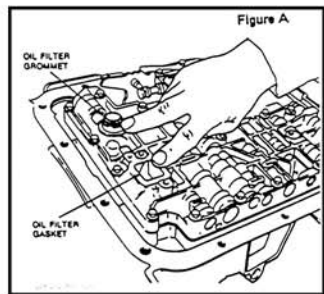
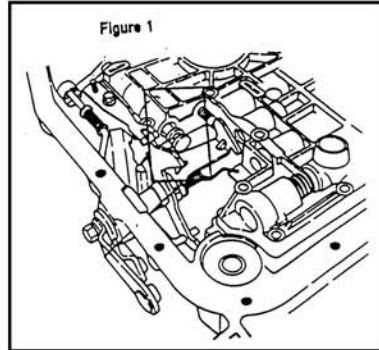

5. Remove excess gasket material from pan mounting area of the case as well as from the pan itself.

6. Tighten pan bolts to 12-16 ft. lbs.

7. With the rear wheels off the ground, add for quarts of Dexron or Type-F transmission oil into the transmission filler tube. Start the engine and put

the shifter in neutral. Check the fluid level and add fluid until it is at the "add" mark found on the dipstick. Shift the transmission through all gear positions 5 times.

8. Lower car to the ground and run through the gears about five or six times. Check the fluid level again and bring to the "full" line.

NOTE: The four front, one center and three rear attaching bolts are shorter than the others.

